

Super Sharpy 420

User Manual



Guangzhou Mitek Light Co.,LTD

Email: info@miteklight.com

Website: www.miteklight.com

Add: No. 21 Dongfeng Avenue, Automobile Industry Base, Huadu District, Guangzhou

TECHNICAL PARAMETERS

Light source

Input voltage: AC110-220V, 50-60Hz; electronic ballast and AC/DC switching power supply.

Display: color LCD display

Keys: touch keys

Bulb: Philips MSD Platinum 420W Lamp

Optical

Lens: Three-layer high-precision multi-group glued optical lens, 6-layer coating

Motor: The latest technology research and development of high-silent motors with high-tech drive software, so that each functional motor has super-fast response and accurate positioning under silent movement, and users can easily achieve fast scene switching during use

Speed: X-axis can reach 2.2/S; Y-axis can reach 1.1/S

Strobe: Turn off the strobe, the lamp automatically half-power, energy saving and environmental protection,

Electric focus, beam angle 0~2.4°;

Controls

Control channel: 14CH/17CH;16CH/20CH.

Effect

Color: Italian color filter, 14 bright and beautiful colors + white light,

Pattern: 17 fixed pattern pieces + white light;

Prism: 8 prisms-16 prisms-8+16 superimposed prisms, moving effect, atomization function; 0~100% mechanical dimming, support mechanical strobe and adjustable speed strobe effect, support strobe macro function;

Construction

Adopting photoelectric reset system, it can automatically retrieve and reset when an accidental misoperation occurs.

Horizontal: 540°, resolution 8Bit/16Bit;

Vertical: 270°, resolution 8Bit/16Bit.

Overheat protection.

Weight&Dimension

Light hook: 2 pcs

Net weight: 15.2KG

Size: 31*31.5*52CM

With automatic error correction reset function;

Chapter 1 Precautions and Installation

1. Maintenance

- This lamp shall be kept dry to avoid working in a wet environment.
- Intermittent use will effectively prolong the life of this lamp.
- In order to obtain good ventilation and lighting effects, please pay attention to cleaning the fan, fan net and lens regularly.
- Do not wipe the lamp housing with organic solvents such as alcohol to avoid damage.

2. Statement

To use this product correctly and safely, please read the instructions carefully before installing and using this product. This manual contains important installation and application information. When installing and operating the product, please strictly follow the operating steps in the manual. At the same time, please keep this manual properly.

This product is in good condition and the packaging is complete when it leaves the factory. All users should strictly abide by the warnings and operating instructions stated above. Any damage caused by misuse is not within the company's warranty, and the dealer is not responsible for any failures and problems caused by ignoring the operating manual. This manual is subject to technical changes without prior notice.

Please carefully remove the packaging, and after removing the packaging, check whether the product has been damaged during transportation, and check whether the following contents are complete.

300W beam light----1 unit

Signal cable----1 unit

Instruction manual----1 unit

Power cord----1 unit

3. Product precautions

- To ensure the service life of the product, do not place the product in a humid or leaking place, and do not operate it in an environment with a temperature above 60 degrees. If the product has been exposed to an extreme unstable temperature environment (such as after transportation), please do not connect the product power supply immediately, because water droplets generated by temperature changes may damage the product. Please use the product after it returns to normal temperature.
- This product can be used in the voltage range of 100-240V and is an indoor product. Please ensure that the ground voltage is not higher than the product can withstand! ! The power plug must be plugged into a well-protected Class I socket. The green or brown conductor must be grounded.
- Please check the power cord of this product regularly. Make sure the power cord is not folded or damaged, and is not connected to other wires! Pay special attention when connecting the power cord or related connections. Be sure to unplug the power cord when not using this product or before cleaning.
- Please do not modify this product without authorization, otherwise it may be damaged and the resulting damage is not covered by the warranty. In addition, unprofessional operation may cause short circuits, burns or electric shocks, etc.
- Do not place this product in a place where it is easy to loosen or shake.

- Before using the product, please familiarize yourself with its operating functions. Please do not shake the product. Do not use brute force when installing or operating the product. Do not allow unprofessionals to operate the product. Most damage is caused by unprofessional operation.
- To avoid the risk of electric shock, please seek professional assistance when repairing this product.
- When the bulb is in use, the power supply voltage change should not exceed $\pm 10\%$. If the voltage is too high, the life of the bulb will be shortened, and if the voltage is too low, the light color of the bulb will be affected.
- After a power outage, the lamp must be fully cooled for 20 minutes before it can be powered on again.
- To ensure the normal use of this product, please read this instruction carefully.
- Signal cable connection (DMX)

Use RS-485 cables that meet the specifications: shielded, 120ohm characteristic impedance, 22-24 AWG, low capacitance. Do not use microphone cables or cables with different specified characteristics. Terminal connections must use 3 or 5-pin XLR type male/female connectors (minimum 1/4 W). Figure 1 shows a schematic diagram of signal line connection (the lamp in the figure is an example picture and does not represent the actual appearance of this product).

IMPORTANT: The wires must not touch each other or the metal housing.

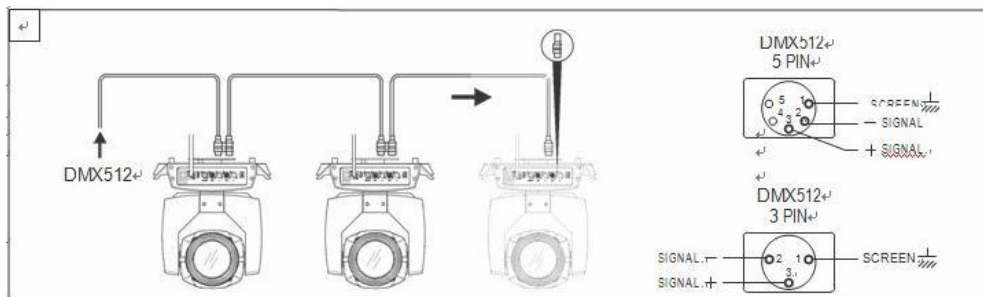
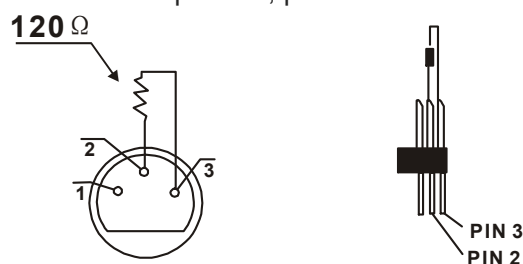

Figure 1 DMX signal line connection diagram

During the installation process, if the signal line is laid for a long distance or in an environment with noisy electrical appliances, such as a dance hall, it is recommended to use a DMX terminator (loop connection). This can avoid the turbidity of the digital control signal caused by electrical noise. The DMX terminator is composed of a simple XLR connector 2-core and 3-core connected to a 120 ohm resistor. Please insert the terminator into the XLR output port of the last product, please refer to the figure below.



4. Lighting installation

Note: The lamp can be placed horizontally, hung diagonally, or hung upside down. Be sure to pay attention to the installation method when hanging diagonally or upside down.

For greater safety, please hang and install this product away from aisles, seating areas, or areas within reach of people

Before hanging this product, please make sure that the installation point can withstand 10 times the weight of this product.

The product must be installed with a double protection device, such as a safety rope.

When hanging, dismantling or repairing this product, it is forbidden to stand under the installation point.

Please ensure that this product should be installed at least 0.5 meters away from flammable materials.

Please remember to use the safety rope as a safety guarantee to prevent accidents when the lock is loosened.

Hanging point: Top hanging requires the installer to be experienced, including calculating the load-bearing requirements, the installation materials used, and periodically checking the installation materials and the safety of the product. If you lack this knowledge, please do not attempt to install it yourself. If you do not do it correctly, it may cause serious consequences such as personal injury.

Before powering on the product, please ensure that all required hanging and installation steps are completed.

Quick-lock hanging: There is a specially designed professional hanging piece at the bottom of this product, including a quick-lock hanging piece and a safety rope hanging point (please refer to the figure below).

When hanging this product on a truss, please remember to use a suitable quick lock, fix it to the quick lock hanging position of the product, and hang it with M10 screws. To further ensure safety, please install the safety rope to the safety rope hanging point at the bottom of the product and fix it to the truss.

As shown in Figure 2, (the lamp in the picture is an example picture and does not represent the actual appearance of this product) before positioning the lamp, ensure the stability of the installation site. When reversing the hanging installation, make sure that the lamp does not fall off the support frame. A safety rope needs to be passed through the support frame and the lamp handle for auxiliary hanging to ensure safety and prevent the lamp from falling and sliding.

During the installation and debugging of the lamps, pedestrians are prohibited from passing below, and the safety ropes are regularly checked for wear and tear and the hook screws are loose.

If the lamps fall due to unstable hanging installation, our company will not bear any responsibility for any consequences.

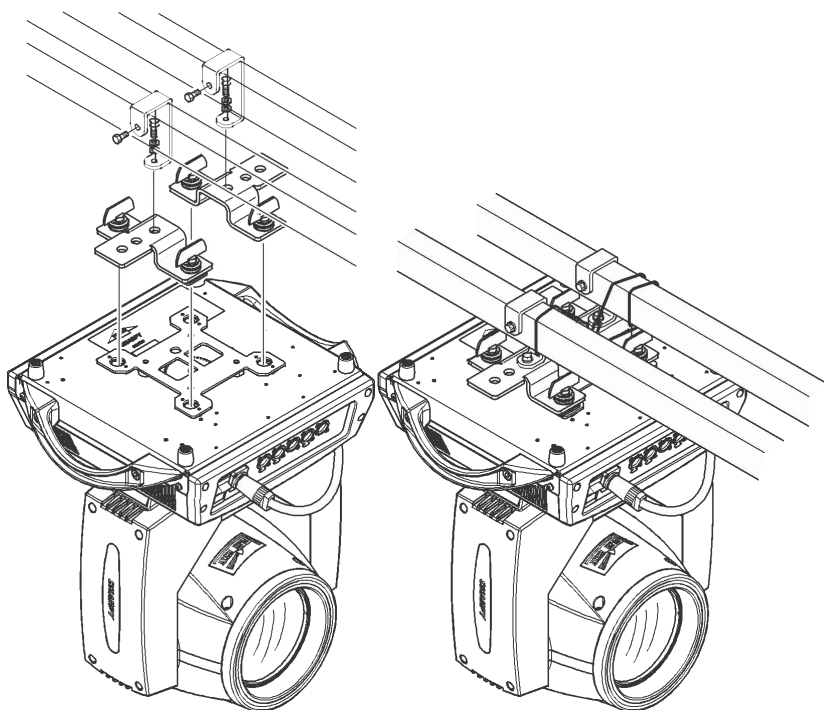

Figure 2 Schematic diagram of inverted lamp

Chapter 2 Panel Operation

1. Lighting panel

The schematic diagram of the lighting panel is shown in Figure 3:

- 1) Address code: The display range is 001-512, and the address code shown in the figure is 001.
- 2) DMX mode: 512 mode.
- 3) Buttons: UP: Up button
MENU: Return button
ENTER: Confirm button
DOWN: Down button

Note: Do not use pointed or sharp objects to hit the display screen to avoid damage.



Figure 3 Schematic diagram of the four-button display panel

2. Menu home page

The first menu interface contains 8 submenus. Use the "UP" and "DOWN" keys to select the corresponding submenu, and click the "ENTER" key to enter the corresponding submenu interface. The first menu interface is shown in Figure 4:

- 1) DMX settings: Click to enter the address code setting. Use the "UP" and "DOWN" keys to increase or decrease the address code by one digit. At this time, the address code displayed on the lighting panel will also be updated synchronously.
- 2) Equipment settings: Click to enter the equipment settings to operate the reverse switch of the X-axis/Y-axis and the switch for the X/Y-axis out-of-step correction.
- 3) Bulb settings: Click to enter the bulb settings to control the bulb switch and the power-on lighting settings.
- 4) Display settings: Click to enter the display settings to adjust the display direction and switch between Chinese and English.
- 5) Equipment test: Click to enter the equipment test to control the operation mode of the equipment. Through the manual mode, the functions of the lamps can be controlled. For details, see the channel table.
- 6) Device information: Click to enter to view the device usage time, lamp usage time, lamp reset time, error information display, product code, test mode, fan speed and other information.
- 7) Reset function: Click to enter to operate the motor power switch and the reset function of the XY axis, strobe, color, pattern, and focus motor.
- 8) Advanced settings: Click to enter the password to enter the calibration interface and set the calibration parameters. Enter fine-tuning recovery to control whether the calibration data is restored.



Figure 4 Confirm input window

The system setting interface is shown in Figure 4. Enter the main menu, click the "ENTER" key to select the setting to be modified, then use the "UP" and "DOWN" keys to select the content to be changed, and finally press the "ENTER" key to confirm. You can change the working mode, working parameters and panel display settings of the lamp. For specific details, see Table 1.

Main Menu	Secondary menu	Level 3 menu/parameters	Functional Description
DMX Settings	DMX address code	001	Set address code; range 14CH:1-499 17CH:1-496
	DMX address code	14CH/17CH	Two channel modes available
	DMX Final Status	Keep	Keep the last frame of DMX signal data
		Standby	Maintain manual test channel data
	Observe the DMX channel value	none	Display the received DMX channel value
Device Setup	X-axis reverse	open	X-axis reverse open
		close	X-axis reverse close
	Y-axis reverse	open	Y-axis reverse open
		close	Y-axis reverse close
	X/Y axis step-out correction	open	XY axis out-of-step correction function is enabled
		close	XY axis out-of-step correction function is disabled
Light bulb setting	Light bulb switch	open	Manual lighting
		close	Manual light off
	Lamp status at power on	open	The power-on light function is turned on
		close	Turn on the light function off
Display Settings	Show reverse	automatic	Display orientation is controlled by gravity
		open	Display direction fixed positive

		close	Display direction fixed reverse
	language	Chinese /EN	Switch between Chinese and English
Equipment Testing	move	DMX	Controlled by DMX signal
		User Programs	It is controlled by the built-in program and acts as a master to send data to slaves in DMX mode.
		Automated testing	It is controlled by the built-in test program and acts as a master to send data to slaves in DMX mode.
	manual mode	Manual control of the channel values	000-255
Device Information	Device usage time	00000000.0H	The cumulative running time of the equipment after it is powered on
	Lamp usage time	00000000.0H	Bulb lighting time
	Reset lamp hours	none	Clear lamp usage time
	product code	BEAM 420-AA.BB	AA: Display board version number BB: Motor board version number
		UID:380640F03B16	Native UID number
		SN:1F2398952827	Native SN serial number
	wrong	Error message display	
	test pattern	Fan test (fan 01 100%)	Manual control of fan speed
		XY axis speed (x0.01/sec)	Display the XY axis motor running speed
Fan speed	Display fan speed value		
Reset function	Motor power supply	open	All motors powered
		close	All motors powered off
	XY axle	XY axis motor reset	
	Strobe	Strobe reset	
	color	Color disk motor reset	
	pattern	Gobo motor reset	
	Optical Path	Focus motor reset	
advanced setup	Fine-tuning	Enter password, lamp calibration	Calibration parameter settings
	Fine-tuning recovery	confirm	Calibration data restore default values
		Cancel	Cancel an operation

2.1 DMX Settings

DMX设置	
DMX地址码:	001
DMX通道模式:	14CH
DMX最后状态:	保持
观察DMX通道值	

Figure 5 System settings interface

2.2 2.2 Equipment Setup

设备设置	
X轴反向	关
Y轴反向	关
X/Y轴失步纠正	开

Figure 6 Device settings interface

2.3 Bulb Settings

灯泡设置	
灯泡开关	关
上电时灯泡状态	关

Figure 7 Light bulb setting interface

2.4 Display Settings

显示设置	
显示反向	自动
语言	中文

Figure 8 Display settings interface

2.5 Equipment Testing

设备测试	
运行	DMX
手动模式	

Figure 9 Device test interface

手动模式		手动模式		手动模式	
1. X轴	000	7. 棱镜1自转	000	13. 调光	000
2. Y轴	000	8. 棱镜2	000	14. 功能	000
3. XY速度	000	9. 棱镜2自转	000		
4. 颜色	000	10. 雾化棱镜3	000		
5. 图案	000	11. 调焦	000		
6. 棱镜1	000	12. 频闪	000		

Figure 10 Manual mode interface

2.6 Device Information

设备信息
设备使用时间: 00000000.0h
灯泡使用时间: 00000000.0h
复位灯泡时间
产品编码
错误
测试模式
风扇转速

Figure 11 Device information interface

Press the "ENTER" key directly to enter the device information interface. Use the "UP" and "DOWN" keys to select the information you want to view, and then click "ENTER" to view the corresponding content. The system calibration interface is shown in Figure 11, and the detailed content is shown in Table 2.

option	illustration	
Device usage time	00000000.0H	The cumulative running time of the equipment after it is powered on
Lamp usage time	00000000.0H	Bulb lighting time
Reset lamp hours	none	Clear lamp usage time
product code	BEAM 420-AA.BB	AA: Display board version number BB: Motor board version number
	UID:380640F03B16	Native UID number
	SN:1F2398952827	The SN serial number of the machine
error	The error message is displayed	

Test Mode	Fan test (fan 01 100%)	Manual control of fan speed
	XY axis speed (x0.01/sec)	Display the XY axis motor running speed
Fan speed	Display fan speed value	

2.7 Reset Function



Figure 12 Reset function interface

The reset function interface is shown in Figure 12. Press the "UP" and "DOWN" keys to switch the reset mode. Press "ENTER" to reset directly. For details, see Table 3.

Options	illustration	
Motor power supply	open	All motors powered
	close	All motors powered off
XY axle	XY axis motor reset	
Strobe	Strobe reset	
color	Color disk motor reset	
pattern	Position reset of the pattern disc motor	
Optical Path	Focus motor reset	

2.8 System Calibration

系统校准		系统校准		系统校准	
X轴起点	127	色盘	127	雾化半步	127
X轴行程	127	图案	127	雾化行程	127
Y轴起点	127	棱镜1半步	127	棱镜3行程	127
Y轴行程	127	棱镜1行程	127	调焦起点	127
频闪起点	127	棱镜2半步	127	调焦行程	127
频闪行程	127	棱镜2行程	127		

Figure 13 System calibration interface

Enter the password "6688" to enter the system calibration interface. Use the "UP" and "DOWN" keys to modify the values. You can modify the lamp power and motor travel parameters. The system calibration interface is shown in Figure 13. For details, see Table 4.

Options	illustration
Initial Position	After entering the sub-interface, you can adjust the initial position of the X-axis, Y-axis, strobe, color disk, image disk, prism, atomization, and focus motor. The adjustment range is 0~255, 127 means no adjustment
Stroke calibration	After entering the sub-interface, you can adjust the X-axis, Y-axis, strobe, color disk, image disk, prism, atomization, and focus motor stroke. The adjustment range is 0~255, 127 means no adjustment

Chapter 3 Channel Description and Technical Parameters

1. Channel table

14CH/17CH

14CH	17CH	Channel Name	Channel Value	Channel Function
1	1	X axis	0-255	0-540degree
	2	X-axis fine adjustment	0-255	0-2degree
2	3	Y axis	0-255	0-270degree
	4	Y-axis fine adjustment	0-255	0-1degree
3	5	XY degree	0-255	From fast to slow
4	6	color	0-11	White

			12-15	color1
			16-19	color2
			20-23	color3
			24-27	color4
			28-31	color5
			32-35	color6
			36-39	color7
			40-43	color8
			44-47	color9
			48-51	color10
			52-55	color11
			56-59	color12
			60-63	color13
			64-67	color14
			68-71	White+color1
			72-75	color1+color2
			76-79	color2+color3
			80-83	color3+color4
			84-87	color4+color5
			88-91	color5+color6
			92-95	color6+color7
			96-99	color7+color8

			100-103	color8+color9
			104-107	color9+color10
			108-111	color10+color11
			112-115	color11+color12
			116-119	color12+color13
			120-123	color13+color14
			124-127	color14+White
			128-189	Counterclockwise flow from fast to slow
			190-193	Stop water flow
			194-255	Clockwise flow from slow to fast
5	7	pattern	0-7	White light hole
			8-14	pattern1
			15-21	pattern2
			22-28	pattern3
			29-35	pattern4
			36-42	pattern5
			43-49	pattern6
			50-56	pattern7
			57-63	pattern8
			64-70	pattern9
			71-77	pattern10
			78-84	pattern11

			85-91	pattern12
			92-98	pattern13
			99-105	pattern1Jitter from slow to fast
			106-112	pattern2Jitter from slow to fast
			113-119	pattern3Jitter from slow to fast
			120-126	pattern4Jitter from slow to fast
			127-133	pattern5Jitter from slow to fast
			134-140	pattern6Jitter from slow to fast
			141-147	pattern7Jitter from slow to fast
			148-154	pattern8Jitter from slow to fast
			155-161	pattern9Jitter from slow to fast
			162-168	pattern10Jitter from slow to fast
			169-175	pattern11Jitter from slow to fast
			176-182	pattern12Jitter from slow to fast
			183-189	pattern13Jitter from slow to fast
			190-221	Counterclockwise flow from fast to slow
			222-223	Stop water flow
			224-255	Clockwise flow from slow to fast
6	8	Prism1	0-127	Remove the prism
			128-255	Insert prism1
7	9	Prism1rotation	0-127	0-400degree
			128-190	Forward flow from fast to slow

			191-193	stop
			194-255	Reverse flow from slow to fast
8	10	Prism2	0-127	Remove the prism
			128-255	Insert prism2
9	11	Prism2rotation	0-127	0-400degree
			128-190	Forward flow from fast to slow
			191-193	stop
			194-255	Reverse flow from slow to fast
10	12	Atomization/Prism3	0-127	none
			128-192	Atomized cutting
			193-255	16 Prism cut-in
11	13	focusing	0-255	From far to near
	14	Focus fine adjustment	0-255	Focus fine-tuning
12	15	Strobe	0-3	Turn off the light
			4-103	Synchronous strobe
			104-107	switch
			108-207	Bisection strobe
			208-212	Turn on the light
			213-251	Random strobe
			252-255	Turn on the light
13	16	Dimming	0-255	0-100%Dimming
14	17	Function	130-139	Turn on the light bulb for more than 5 seconds

			140-149	XY motor reset after more than 5 seconds
			150-159	The motor resets after more than 5 seconds
			200-209	All motors reset after more than 5 seconds
			230-239	Turn off the light bulb for more than 5 seconds

16CH/20CH

16CH	20CH	Channel Name	Channel Value	Channel Function
1	1	color	0-11	white
			12-15	white+color1
			16-19	color1
			20-23	color1+color2
			24-27	color2
			28-31	color2+color3
			32-35	color3
			36-39	color3+color4
			40-43	color4
			44-47	color4+color5
			48-51	color5
			52-55	color5+color6
			56-59	color6
			60-63	color6+color7
			64-67	color7
			68-71	color7+color8
			72-75	color8
			76-79	color8+color9
80-83	color9			
84-87	color9+color10			

			88-91	color10
			92-95	color10+color11
			96-99	color11
			100-103	color11+color12
			104-107	color12
			108-111	color12+color13
			112-115	color13
			116-119	color13+color14
			120-123	color14
			124-127	color14+white
			128-189	Counter-clockwise water flow from fast to slow
			190-193	Stop the water flow
			194-255	Clockwise water flow from slow to fast
2	2	Strobe	0-3	Turn off the light
			4-103	Synchronous strobe
			104-107	switch
			108-207	Bisector flicker
			208-212	opening the light
			213-251	Random flickering
			252-255	opening the light
3	3	dimming	0-255	0-100% dimming
4	4	Fixed pattern	0-7	White light hole
			8-14	Pattern 1
			15-21	Pattern 2
			22-28	Pattern 3
			29-35	Pattern 4
			36-42	Pattern 5
			43-49	Pattern 6
			50-56	Pattern 7
			57-63	Pattern 8
			64-70	Pattern 9

			71-77	Pattern 10
			78-84	Pattern 11
			85-91	Pattern 12
			92-98	Pattern 13
			99-105	pattern1 Shaking from slow to fast
			106-112	pattern2 Shaking from slow to fast
			113-119	pattern3 Shaking from slow to fast
			120-126	pattern4 Shaking from slow to fast
			127-133	pattern5 Shaking from slow to fast
			134-140	pattern6 Shaking from slow to fast
			141-147	pattern7 Shaking from slow to fast
			148-154	pattern8 Shaking from slow to fast
			155-161	pattern9 Shaking from slow to fast
			162-168	pattern10 Shaking from slow to fast
			169-175	pattern11 Shaking from slow to fast
			176-182	pattern12 Shaking from slow to fast
			183-189	pattern13 Shaking from slow to fast
			190-221	Counter-clockwise water flow from fast to slow
			222-223	Stop the water flow
			224-255	Clockwise water flow from slow to fast
5	5	prism1	0-127	Remove the prism
			128-255	Insert 8-prism
6	6	Prism 1 rotation	0-127	0400 degrees
			128-190	Forward flow of water from fast to slow
			191-193	stop
			194-255	Reverse flow of water from slow to fast
7	7	Prism 2	0-127	Remove the prism
			128-255	Insert 8+16 double prism
8	8	Prism 2 rotation	0-127	0400 degrees
			128-190	Forward flow of water from fast to slow

			191-193	stop
			194-255	Reverse flow from slow to fast
9	9	focus	0-255	From far to near
10	10	x-axis	0-255	0-540 degree
11	11	X-axis fine-tune	0-255	0-2 degree
12	12	Y-axis	0-255	0-270 degree
13	13	Y-axis fine-tuning	0-255	0-1 degree
14	14	Atomizing- Prism 3	0-127	Atomize-Prism 3 Cutout
			128-192	Atomized Cut-in
			193-255	Prism 3 Cut-in
15	15	reset	140-149	Reset XY motor after 5 seconds
			150-159	Reset motor after 5 seconds
			200-209	Reset all motors after 5 seconds
16	16	Light bulb control	0-25	empty
			26-100	Turn off the bulb for more than 5 seconds
			101-255	Turn on the bulb for more than 5 seconds
	17	XY speed	0-255	From fast to slow
	18	Color speed	0-255	From fast to slow
	19	Focus speed	0-255	From fast to slow
	20	Fixed pattern speed	0-255	From fast to slow

Chapter 4 Common Faults and Usage Precautions

1. Common fault handling

The lamp contains professional components such as microcomputer circuit boards and high-voltage power supplies. For your safety and product life, non-professionals should not disassemble the lamp and related accessories without authorization.

1. The bulb does not light up (except LED light sources)

Possible reasons: The bulb has not completely cooled down, or the bulb has reached its lifespan. The following are the solutions:

- Due to abnormal operation, the bulb is not completely cooled, the light body should be cooled for more than 10 minutes, so that its internal completely restored to the normal state, and then start the power supply again;
- Check whether the light bulb has reached the service life, and replace it with a new light bulb;

- Check whether the bulb and lamp device line leakage, fall off or poor contact;
- Replace the new lamp lighter.

2. The light beam appears dim

Possible reasons: The bulb has been used for a long time or the light path is not clean. The solution is as follows:

- Check whether the light bulb has reached the service life, and replace it with a new light bulb;
- Check whether the optical components or bulbs are clean, and whether there is dust accumulation on the bulbs and other optical components, and the bulbs and the components should be cleaned and maintained regularly.

3. Pattern projection is blurred

- Check whether the electronic focus channel value is appropriate for the current projection distance.

4. The lamp works intermittently

Possible cause: The internal circuit enters the protection state, and the solution is as follows:

- Check whether the fan is running normally or whether it is dirty, causing the temperature inside the lamp to rise;
- Check whether the internal temperature control switch is in a closed state;
- Check whether the bulb has reached its service life and replace it with a new one

5. After the lamp is reset normally, it does not accept the control of the console.

Possible reasons: signal line failure or abnormal lamp parameter settings, the solution is as follows:

- Check the starting address code and the connection of DMX signal line (whether the signal cable is intact and whether the Alcock head connection is loose);
- Add a signal amplifier, add 120 ohm terminal resistance;

6. The lamp cannot be started

Possible cause: The power line is bad, the solution is as follows:

- Check whether the insurance on the power input socket is fused and replace the insurance;
- Poor line contact of lamp travel due to vibration during long-distance transportation
- Check the input power supply, computer board and other plug-in devices.

2. Precautions for use

- Check whether the local power supply meets the rated voltage requirements of the product, and whether the leakage protector and overcurrent protector meet the requirements of the load;
- Do not use damaged power cord with insulation and do not attach power cord to other wires;
- The lamps and lanterns use strong air refrigeration, which is easy to accumulate dust. They must be cleaned once a month, especially the cooling outlet, otherwise it will be blocked due to dust, resulting in poor heat dissipation, so that the lamps appear abnormal.

- When installing lamps, the fixing screws must be tightened, and safety ropes should be added, and checked regularly;
- In the installation and positioning of the lamp, any point on the surface of the lamp and any burning explosive, keep the minimum distance of 10 meters, the distance from the irradiation is 2.5 meters, please do not install the lamp directly on the surface of combustible material;
- It is recommended that the continuous working time of lamps should not exceed 10 hours, and the interval time of continuous starting lamps should not be less than 10 minutes, otherwise it will not be triggered normally because of the overheating protection of the bulb;
- The closing time of using the on-off valve should not exceed 5 minutes. If the light needs to be closed for a long time, the console (light gun control channel) should be used to turn off the light gun;
- In order to ensure that multiple lamps better comply with the scene effect, the lamps should not always be in an unfinished current scene, that is, start the next scene action, preferably this state should not exceed 3 minutes to ensure that multiple lamps can run synchronously;
- In the process of use, if the lamps are abnormal, the lamps should be stopped in time to prevent other faults.

3. Notes on using RDM

RDM is an extended version of the DMX512-A protocol and a remote device management protocol. Traditional DMX512 protocol communication is one-way communication and is based on the RS-485 bus. RS-485 is a time-division multipoint, half-duplex protocol that only allows one port to output to the host at the same time. Therefore, pay attention to the following points when using RDM:

- To use the console or host device that supports the RDM protocol host;
- To use a two-way signal amplifier, the traditional one-way signal amplifier is not suitable for RDM protocol, because the RMD protocol requires feedback data, and the use of one-way amplifier will block the return data, resulting in the search for the lamp;
- All lamps must be set to DMX mode to ensure that there is only one host on the signal line;
- A 120 ohm impedance matching resistance must be inserted between terminals 2 and 3 of the terminal plug. When the signal line is relatively long, the signal reflection, which is conducive to the quality of communication;
- When the lamp is subject to DMX control, but can not RDM search the lamp, first check the signal amplifier, and then check whether the 2 and 3 lines of the signal line have poor contact.

REMARK

The product has perfect performance and integrity packing.

All users should be strictly comply with the warning and operating instructions as stated.

Or we aren't in charge of any result by misusing.

Any damage resulting by misuse is not within the Company's warranty.

Any fault or problem caused by neglecting the manual is also not in the charge of dealers.

Errors and omissions for every information given in this manual excepted.

All information is subject to change without prior notice.