

Moving stromy 1500 PRO

User Manual



Guangzhou Mitek Light Co.,LTD

Email: info@miteklight.com

Website: www.miteklight.com

Add: No. 21 Dongfeng Avenue, Automobile Industry Base, Huadu District, Guangzhou

TECHNICAL PARAMETERS

Light source

Power Supply: AC 100-240V, 50/60Hz

Power Consumption: 1500W

Light Source: 768 x 1.5W White LEDs, 528 x 1.5W RGB 3-in-1 LEDs

Segment Control: White (4 x 12 groups), Color (3 x 6 groups)

Optical

CRI: Ra ≥ 80

LED Lifespan: 20,000 hours

Beam Angle: 110°

Controls

DMX Channels: 25CH / 34CH / 68CH / 114CH / 130CH / 170CH

Control Modes: DMX512, Auto, Master/Slave, Sound Active

Display: Touchscreen LCD

Protocols: Art-Net, DMX512, RDM

RDM: Bi-directional Communication

Effect

Dimming: 0-100% Linear Dimming / 4 Selectable Dimming Curves

Construction

Tilt Angle: 185° (Y-axis adjustable)

Cooling: Temperature-controlled, Overheat Protection

DMX I/O Sockets: Seetronic Waterproof 3-pin In/Out

Art-Net: Seetronic Art-Net In/Out

Power Socket: Seetronic Waterproof Power Input

Seetronic USB Port

IP Rating: IP66

Weight&Dimension

Product size: 40.4 * 20.2 * 35cm

Net Weight: 15kg

Carton packaging: 50*25*44cm (1in1)

Gross Weight: 17kg

Flycase packaging: 117*51*62cm(4in1)

Gross weight: 93kg

SIZE DRAWING

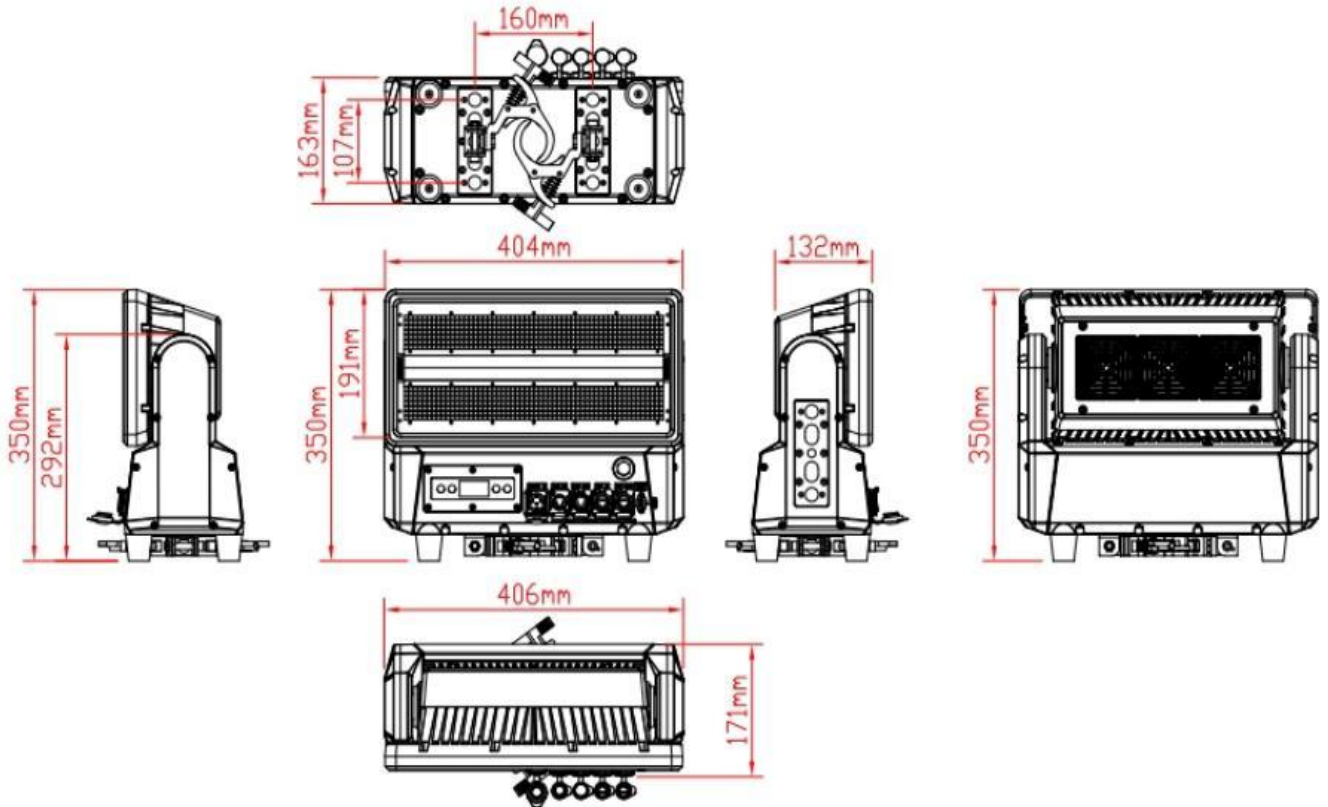

STATEMENT

The product has well capability and intact packing when leave factory. All of the user should comply with warning item and manual, any misuse cause of the damages are not included in our guarantee, and also can not beresponsible for any malfunction & problem owing to ignore the manual.

Safety Instruction

Please keep this User Guide for future consultation. If you sell the unit to another user, be sure that they also receive this instruction booklet.

Unpack and check carefully there is no transportation damage before using the unit.

Before operating, ensure that the voltage and frequency of power supply match the power requirements of the unit.

It's important to ground the yellow/green conductor to earth in order to avoid electric shock.

The unit must be installed in a location with adequate ventilation, at least

50cm from adjacent surfaces. Be sure that no ventilation slots are blocked. Disconnect main power before replacement or servicing.

Make sure there are no flammable materials close to the unit while operating as it is fire hazard.

Use safety cable when fixes this unit. DO NOT handle the unit by taking its head only, but always by taking its base.

Maximum ambient temperature is Ta: 40°C . DO NOT operate it where the temperature is higher than this Unit surface temperature may reach up to 85°C . DO NOT touch the housing bare-hand during its operation. Turn off the power and allow about 15 minutes for the unit to cool down before replacing or serving.

In the event of serious operating problem, stop using the unit immediately. Never try to repair the unit by yourself. Repairs carried out by unskilled people can lead to damage or malfunction. Please contact the nearest authorized technical assistance center. Always use the same type spare parts. DO NOT touch any wire during operation as high voltage might be causing electric shock.

WARNING:

To prevent or reduce the risk of electrical shock or fire, do not expose the unit to rain or moisture. DO NOT open the unit within five minutes after switching off.

The housing, the lenses, or the ultraviolet filter must be replaced if they are visibly damaged.

CAUTION:

There are no user serviceable parts inside the unit. DO NOT open the housing or attempt any repairs yourself. In the unlikely event your unit may require service, please contact your nearest dealer.

INSTALLATION:

The unit should be mounted via its screw holes on the bracket. Always ensure that the unit is firmly fixed to avoid vibration and slipping while operating. And make sure that the structure to which you are attaching the unit is secure and is able to support a weight of 10 times of the unit's weight. Also always use a safety cable that can hold 12 times of the weight of the unit when installing the fixture. The equipment must be fixed by professionals. And it must be fixed at a place where is out of the touch of people.

How to Control The Device

The DMX512 is widely used in intelligent lighting control, with a DMX 512 controller. connect several lights together, dmx in and dmx out, 3 pin XLR connectors: Pin 1: GND, Pin 2: Negative signal (-), Pin 3: Positive signal (+)

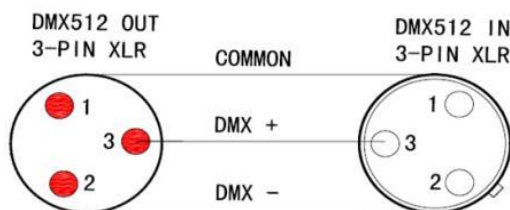
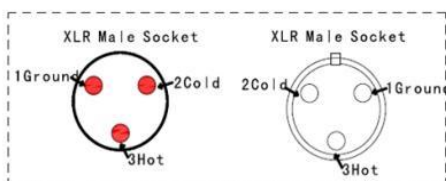

Figure2



XLR Pin Configuration
pin1=Ground
pin2=Data Compliment (negative)
pin3=Data true(positive)

Display:

- MENU To select the programming functions
- DOWN To go backward in the selected functions
- UP To go forward in the selected functions
- ENTER To confirm the selected functions

Set DMX Address Code

1. Press "**Menu**" to "Set DMX Address",and press "**ENTER**" keys to enter into
2. Show "Set DMX Address DMX Address:001",Press the "**UP** and **DOWN**" keys to amended
3. Press "**ENTER**" keys to save and Exit,Press the "**MENU**" Keys does not save and Exit
4. Functions setting via OLED display panel as below

NO	Main Menu	Programming Levels	
1	Protocol	DMX512/Art-Net/sACN/AUTO	
2	DMX Address	001-512	
3	DMX Channel	25CH/34CH/68CH/114CH/130CH/170CH	
4	Static	Tilt	000-255
		Frost	000-255
		Dimmer	000-255
		Red	000-255
		Green	000-255
		Blue	000-255
		White	000-255
5	TiTt Offset	000-255	
6	TiTt Invert	No/Yes	
7	Pixel Invert	Plate1 Invert	No/Yes
		Plate2 Invert	No/Yes
		Plate3 Invert	No/Yes
		Tube1 Invert	No/Yes
		Tube2 Invert	No/Yes
		Tube3 Invert	No/Yes
		Tube4 Invert	No/Yes
8	Led Swap	Plate Swap	No/Yes
		Tube Swap	No/Yes
9	Master/Slave	Master/Slave	
10	Dimmer Mode	OFF/Mode1/Mode2/Mode3	
11	Dimmer Curve	Linear/Square/Inverse Square/S-Curve	
12	White Balance	Switch	On/Off
		R	000-255
		G	000-255
		B	000-255
13	led Frequency	16KHz/32KHz	
14	Fan Mode	Auto/On	

15	Display Invert	No/Yes		
16	Back Light	Always On/2Min/30S/10S		
17	Language	Ch / En		
18	Key Lock (pass: 8888)	On/Off		
19	Ethernet Setting	IP Address	000.000.000.000	
		Subnet MASK	000.000.000.000	
		ArtNet	Net	
			SubNet	
			Universe	
			Prot	
SACN	Universe			
20	Information	Version		
		Now Temp		
		Max Temp		
21	Factory Reset	No/Yes		

DMX Channel Tablee

DMX 512 25CHs

CH	Function	Value	Percent/Setting
1	Tilt	000-255	0-100%
2	Fine tilt	000-255	0-100%
3	Frost	000-255	0-100%
4	RGB Dimmer	000-255	0-100%
5	RGB Dimmer Fine	000-255	0-100%
6	RGB Strobe	000-019	Strobe Off
		020-024	Strobe Open
		025-064	Strobe from slow to fast
		065-069	Strobe Open
		070-084	Strobe 100-0% from fast to slow
		085-089	Strobe Open
		090-104	Strobe 0-100% from fast to slow
		105-109	Strobe Open
		110-124	Random strobe from slow to fast
		125-129	Strobe Open
		130-144	Random strobe 100-0% from slow to fast
		145-149	Strobe Open
		150-164	Random strobe 0-100% from slow to fast
		165-169	Strobe Open
		170-184	Pulse strobe 1 from fast to slow
185-189	Strobe Open		

		190-204	Random pulse strobe from slow to fast
		205-209	Strobe Open
		210-224	Strobe 100-0-100% from fast to slow
		225-229	Strobe Open
		230-244	Pulse strobe 1 from slow to fast
		245-255	Strobe Open
7	White Dimmer	000-255	0-100%
8	White Dimmer Fine	000-255	0-100%
9	White Strobe	000-019	Strobe Off
		020-024	Strobe Open
		025-064	Strobe from slow to fast
		065-069	Strobe Open
		070-084	Strobe 100-0% from fast to slow
		085-089	Strobe Open
		090-104	Strobe 0-100% from fast to slow
		105-109	Strobe Open
		110-124	Random strobe from slow to fast
		125-129	Strobe Open
		130-144	Random strobe 100-0% from slow to fast
		145-149	Strobe Open
		150-164	Random strobe 0-100% from slow to fast
		165-169	Strobe Open
		170-184	Pulse strobe 1 from fast to slow
		185-189	Strobe Open
		190-204	Random pulse strobe from slow to fast
		205-209	Strobe Open
		210-224	Strobe 100-0-100% from fast to slow
		225-229	Strobe Open
230-244	Pulse strobe 1 from slow to fast		
245-255	Strobe Open		
10	Red	000-255	0-100%
11	Green	000-255	0-100%
12	Blue	000-255	0-100%
13	White	000-255	0-100%
14	RGB Effect	000-015	None
		016-255	RGB effect selection
15	RGB Effect Speed	000-080	Direction 1, the speed from fast to slow
		081-160	Direction 2, the speed from fast to slow
		161-255	Direction 3, the speed from fast to slow
16	RGB Effect Gradual change	000-255	From fast to slow
17	RGB Effect Background Color	000-255	RGB Background Color Selection

18	RGB Effect Background Dimmer	000-255	Background color dimmer 0-100%
19	RGB Effect Background Dimmer Fine	000-255	Background color dimmer fine 0-100%
20	White Effect	000-015	None
		016-255	White effect selection
21	White Effect Speed	000-040	Direction 1, the speed from fast to slow
		041-080	Direction 2, the speed from fast to slow
		081-120	Direction 3, the speed from fast to slow
		121-160	Direction 4, the speed from fast to slow
		161-200	Direction 5, the speed from fast to slow
		201-255	Direction 6, the speed from fast to slow
22	White Effect Gradual change	000-255	From fast to slow
23	Dimmer Mode	000-020	None
		021-040	Off
		041-060	Dimmer 1
		061-080	Dimmer 2
		081-100	Dimmer 3
		101-255	None
24	Dimmer Curve	000-020	None
		021-040	Linear
		041-060	Index
		061-080	Logarithm
		081-100	S-Surve
		101-255	None
25	Reset	000-250	None
		251-255	Reset after 5s

DMX 512 34CHs

CH	Function	Value	Percent/Setting
1	Tilt	000-255	0-100%
2	Fine tilt	000-255	0-100%
3	Frost	000-255	0-100%
4	RGB Dimmer	000-255	0-100%
5	RGB Dimmer Fine	000-255	0-100%
		000-019	Strobe Off
		020-024	Strobe Open
		025-064	Strobe from slow to fast
		065-069	Strobe Open
		070-084	Strobe 100-0% from fast to slow

6	RGB Strobe	085-089	Strobe Open
		090-104	Strobe 0-100% from fast to slow
		105-109	Strobe Open
		110-124	Random strobe from slow to fast
		125-129	Strobe Open
		130-144	Random strobe 100-0% from slow to fast
		145-149	Strobe Open
		150-164	Random strobe 0-100% from slow to fast
		165-169	Strobe Open
		170-184	Pulse strobe 1 from fast to slow
		185-189	Strobe Open
		190-204	Random pulse strobe from slow to fast
		205-209	Strobe Open
		210-224	Strobe 100-0-100% from fast to slow
		225-229	Strobe Open
		230-244	Pulse strobe 1 from slow to fast
		245-255	Strobe Open
7	White Dimmer	000-255	0-100%
8	White Dimmer Fine	000-255	0-100%
9	White Strobe	000-019	Strobe Off
		020-024	Strobe Open
		025-064	Strobe from slow to fast
		065-069	Strobe Open
		070-084	Strobe 100-0% from fast to slow
		085-089	Strobe Open
		090-104	Strobe 0-100% from fast to slow
		105-109	Strobe Open
		110-124	Random strobe from slow to fast
		125-129	Strobe Open
		130-144	Random strobe 100-0% from slow to fast
		145-149	Strobe Open
		150-164	Random strobe 0-100% from slow to fast
		165-169	Strobe Open
		170-184	Pulse strobe 1 from fast to slow
		185-189	Strobe Open
		190-204	Random pulse strobe from slow to fast
		205-209	Strobe Open
		210-224	Strobe 100-0-100% from fast to slow
		225-229	Strobe Open
		230-244	Pulse strobe 1 from slow to fast
245-255	Strobe Open		
10	Red 1-6	000-255	0-100%
11	Green 1-6	000-255	0-100%
12	Blue 1-6	000-255	0-100%

13	Red 7-12	000-255	0-100%
14	Green 7-12	000-255	0-100%
15	Blue 7-12	000-255	0-100%
16	Red 13-18	000-255	0-100%
17	Green 13-18	000-255	0-100%
18	Blue 13-18	000-255	0-100%
19	White 1-12	000-255	0-100%
20	White 13-24	000-255	0-100%
21	White 25-36	000-255	0-100%
22	White 37-48	000-255	0-100%
23	RGB Effect	000-015	None
		016-255	RGB effect selection
24	RGB Effect Speed	000-080	Direction 1, the speed from fast to slow
		081-160	Direction 2, the speed from fast to slow
		161-255	Direction 3, the speed from fast to slow
25	RGB Effect Gradual change	000-255	From fast to slow
26	RGB Effect Background Color	000-255	RGB Background Color Selection
27	RGB Effect Background Dimmer	000-255	Background color dimmer 0-100%
28	RGB Effect Background Dimmer Fine	000-255	Background color dimmer fine 0-100%
29	White Effect	000-015	None
		016-255	White effect selection
30	White Effect Speed	000-040	Direction 1, the speed from fast to slow
		041-080	Direction 2, the speed from fast to slow
		081-120	Direction 3, the speed from fast to slow
		121-160	Direction 4, the speed from fast to slow
		161-200	Direction 5, the speed from fast to slow
		201-255	Direction 6, the speed from fast to slow
31	White Effect Gradual change	000-255	From fast to slow
32	Dimmer Mode	000-020	None
		021-040	Off
		041-060	Dimmer 1
		061-080	Dimmer 2
		081-100	Dimmer 3
		101-255	None
33	Dimmer Curve	000-020	None
		021-040	Linear
		041-060	Index

		061-080	Logarithm
		081-100	S-Surve
		101-255	None
34	Reset	000-250	None
		251-255	Reset after 5s

DMX 512 68CHs

CH	Function	Value	Percent/Setting
1	Tilt	000-255	0-100%
2	Fine tilt	000-255	0-100%
3	Dimmer Mode	000-020	None
		021-040	Off
		041-060	Dimmer 1
		061-080	Dimmer 2
		081-100	Dimmer 3
		101-255	None
4	Dimmer Curve	000-020	None
		021-040	Linear
		041-060	Index
		061-080	Logarithm
		081-100	S-Surve
		101-255	None
5	Frost	000-255	0-100%
6	Reset	000-250	None
		251-255	Reset after 5s
7	Total Dimmer	000-255	0-100%
8	RGB 1 Dimmer	000-255	0-100%
9	RGB 1 Dimmer Fine	000-255	0-100%
10	RGB 1 Strobe	000-019	Strobe Off
		020-024	Strobe Open
		025-064	Strobe from slow to fast
		065-069	Strobe Open
		070-084	Strobe 100-0% from fast to slow
		085-089	Strobe Open
		090-104	Strobe 0-100% from fast to slow
		105-109	Strobe Open
		110-124	Random strobe from slow to fast
		125-129	Strobe Open
		130-144	Random strobe 100-0% from slow to fast
		145-149	Strobe Open
		150-164	Random strobe 0-100% from slow to fast
		165-169	Strobe Open
		170-184	Pulse strobe 1 from fast to slow

		185-189	Strobe Open
		190-204	Random pulse strobe from slow to fast
		205-209	Strobe Open
		210-224	Strobe 100-0-100% from fast to slow
		225-229	Strobe Open
		230-244	Pulse strobe 1 from slow to fast
		245-255	Strobe Open
11	Red (RGB-1)	000-255	0-100%
12	Green (RGB-1)	000-255	0-100%
13	Blue (RGB-1)	000-255	0-100%
14	(RGB-1) Effect	000-255	(RGB-1) Effect
15	(RGB-1) Effect Speed	000-255	0-100%
16	RGB-1 Effect	0-255	RGB-1 Effect Gradual change
	Gradual change		
17	RGB-1 Effect Background Color	000-255	RGB-1 Effect Background Color
18	RGB-1 Effect Background Dimmer	000-255	0-100%
19	RGB 2 Dimmer	000-255	0-100%
20	RGB 2 Dimmer Fine	000-255	0-100%
21	RGB 2 Strobe	000-019	Strobe Off
		020-024	Strobe Open
		025-064	Strobe from slow to fast
		065-069	Strobe Open
		070-084	Strobe 100-0% from fast to slow
		085-089	Strobe Open
		090-104	Strobe 0-100% from fast to slow
		105-109	Strobe Open
		110-124	Random strobe from slow to fast
		125-129	Strobe Open
		130-144	Random strobe 100-0% from slow to fast
		145-149	Strobe Open
		150-164	Random strobe 0-100% from slow to fast
		165-169	Strobe Open
		170-184	Pulse strobe 1 from fast to slow
		185-189	Strobe Open
		190-204	Random pulse strobe from slow to fast
		205-209	Strobe Open
210-224	Strobe 100-0-100% from fast to slow		
		225-229	Strobe Open
		230-244	Pulse strobe 1 from slow to fast

		245-255	Strobe Open
22	Red (RGB-2)	000-255	0-100%
23	Green (RGB-2)	000-255	0-100%
24	Blue (RGB-2)	000-255	0-100%
25	(RGB-2) Mode Effect	000-255	(RGB-2) Mode Effect
26	(RGB-2) Effect Speed	000-255	0-100%
27	RGB-2 Effect Gradual change	0-255	RGB-2 Effect Gradual change
28	RGB-2 Effect Background Color	000-255	RGB-2 Effect Background Color
29	RGB-2 Effect Background Dimmer	000-255	0-100%
30	RGB 3 Dimmer	000-255	0-100%
31	RGB 3 Dimmer Fine	000-255	0-100%
32	RGB 3 Strobe	000-019	Strobe Off
		020-024	Strobe Open
		025-064	Strobe from slow to fast
		065-069	Strobe Open
		070-084	Strobe 100-0% from fast to slow
		085-089	Strobe Open
		090-104	Strobe 0-100% from fast to slow
		105-109	Strobe Open
		110-124	Random strobe from slow to fast
		125-129	Strobe Open
		130-144	Random strobe 100-0% from slow to fast
		145-149	Strobe Open
		150-164	Random strobe 0-100% from slow to fast
		165-169	Strobe Open
		170-184	Pulse strobe 1 from fast to slow
		185-189	Strobe Open
		190-204	Random pulse strobe from slow to fast
		205-209	Strobe Open
		210-224	Strobe 100-0-100% from fast to slow
		225-229	Strobe Open
		230-244	Pulse strobe 1 from slow to fast
245-255	Strobe Open		
33	Red (RGB-3)	000-255	0-100%
34	Green (RGB-3)	000-255	0-100%
35	Blue (RGB-3)	000-255	0-100%

36	(RGB-3) Mode Effect	000-255	(RGB-3) Effect Speed
37	(RGB-3) Effect Speed	000-255	0-100%
38	RGB-3 Effect Gradual change	0-255	RGB-3 Effect Gradual change
39	RGB-3 Effect Background Color	000-255	RGB-3 Effect Background Color
40	RGB-3 Effect Background Dimmer	000-255	0-100%
41	White 1 Dimmer	000-255	0-100%
42	White 1 Dimmer	000-255	0-100%
	Fine		
43	White 1 Strobe	000-019	Strobe Off
		020-024	Strobe Open
		025-064	Strobe from slow to fast
		065-069	Strobe Open
		070-084	Strobe 100-0% from fast to slow
		085-089	Strobe Open
		090-104	Strobe 0-100% from fast to slow
		105-109	Strobe Open
		110-124	Random strobe from slow to fast
		125-129	Strobe Open
		130-144	Random strobe 100-0% from slow to fast
		145-149	Strobe Open
		150-164	Random strobe 0-100% from slow to fast
		165-169	Strobe Open
		170-184	Pulse strobe 1 from fast to slow
		185-189	Strobe Open
		190-204	Random pulse strobe from slow to fast
		205-209	Strobe Open
210-224	Strobe 100-0-100% from fast to slow		
225-229	Strobe Open		
230-244	Pulse strobe 1 from slow to fast		
245-255	Strobe Open		
44	White 1	000-255	0-100%
45	White 1 Mode Effect	000-255	White 1 Mode Effect
46	White 1 Effect Speed	000-255	White 1 Effect Speed
47	White 1 Effect Gradual change	0-255	White 1 Effect Gradual change
	Gradual change		
48	White 2 Dimmer	000-255	0-100%

49	White 2 Dimmer Fine	000-255	0-100%
50	White 2 Strobe	000-019	Strobe Off
		020-024	Strobe Open
		025-064	Strobe from slow to fast
		065-069	Strobe Open
		070-084	Strobe 100-0% from fast to slow
		085-089	Strobe Open
		090-104	Strobe 0-100% from fast to slow
		105-109	Strobe Open
		110-124	Random strobe from slow to fast
		125-129	Strobe Open
		130-144	Random strobe 100-0% from slow to fast
		145-149	Strobe Open
		150-164	Random strobe 0-100% from slow to fast
		165-169	Strobe Open
		170-184	Pulse strobe 1 from fast to slow
		185-189	Strobe Open
		190-204	Random pulse strobe from slow to fast
		205-209	Strobe Open
		210-224	Strobe 100-0-100% from fast to slow
225-229	Strobe Open		
230-244	Pulse strobe 1 from slow to fast		
245-255	Strobe Open		
51	White 2	000-255	0-100%
52	White 2 Mode Effect	000-255	White 2 Mode Effect
53	White 2 Effect Speed	000-255	White 2 Effect Speed
54	White 2 Effect Gradual change	0-255	White 2 Effect Gradual change
55	White 3 Dimmer	000-255	0-100%
56	White 3 Dimmer Fine	000-255	0-100%
		000-019	Strobe Off
		020-024	Strobe Open
		025-064	Strobe from slow to fast
		065-069	Strobe Open
		070-084	Strobe 100-0% from fast to slow
		085-089	Strobe Open
		090-104	Strobe 0-100% from fast to slow
		105-109	Strobe Open
		110-124	Random strobe from slow to fast
		125-129	Strobe Open

57	White 3 Strobe	130-144	Random strobe 100-0% from slow to fast		
		145-149	Strobe Open		
		150-164	Random strobe 0-100% from slow to fast		
		165-169	Strobe Open		
		170-184	Pulse strobe 1 from fast to slow		
		185-189	Strobe Open		
		190-204	Random pulse strobe from slow to fast		
		205-209	Strobe Open		
		210-224	Strobe 100-0-100% from fast to slow		
		225-229	Strobe Open		
		230-244	Pulse strobe 1 from slow to fast		
		245-255	Strobe Open		
58	White 3	000-255	0-100%		
59	White 3 Mode Effect	000-255	White 3 Mode Effect		
60	White 3 Effect Speed	000-255	White 3 Effect Speed		
61	White 3 Effect Gradual change	0-255	White 3 Effect Gradual change		
62	White 4 Dimmer	000-255	0-100%		
63	White 4 Dimmer Fine	000-255	0-100%		
64	White 4 Strobe	000-019	Strobe Off		
		020-024	Strobe Open		
		025-064	Strobe from slow to fast		
		065-069	Strobe Open		
		070-084	Strobe 100-0% from fast to slow		
		085-089	Strobe Open		
		090-104	Strobe 0-100% from fast to slow		
		105-109	Strobe Open		
		110-124	Random strobe from slow to fast		
		125-129	Strobe Open		
		130-144	Random strobe 100-0% from slow to fast		
		145-149	Strobe Open		
		150-164	Random strobe 0-100% from slow to fast		
		165-169	Strobe Open		
		170-184	Pulse strobe 1 from fast to slow		
		185-189	Strobe Open		
		190-204	Random pulse strobe from slow to fast		
		205-209	Strobe Open		
				210-224	Strobe 100-0-100% from fast to slow
				225-229	Strobe Open
		230-244	Pulse strobe 1 from slow to fast		
		245-255	Strobe Open		

65	White 4	000-255	0-100%
66	White 4 Mode Effect	000-255	White 4 Mode Effect
67	White 4 Effect Speed	000-255	White 4 Effect Speed
68	White 4 Effect Gradual change	0-255	White 4 Effect Gradual change

DMX 512 114CHs

CH	Function	Value	Percent/Setting
1	Tilt	000-255	0-100%
2	Fine tilt	000-255	0-100%
3	Dimmer Mode	000-020	None
		021-040	Off
		041-060	Dimmer 1
		061-080	Dimmer 2
		081-100	Dimmer 3
		101-255	None
4	Dimmer Curve	000-020	None
		021-040	Linear
		041-060	Index
		061-080	Logarithm
		081-100	S-Surve
		101-255	None
5	Frost	000-255	0-100%
6	Reset	000-250	None
		251-255	Reset after 5s
7	RGB Dimmer	000-255	0-100%
8	RGB Dimmer Fine	000-255	0-100%
9	RGB Strobe	000-019	Strobe Off
		020-024	Strobe Open
		025-064	Strobe from slow to fast
		065-069	Strobe Open
		070-084	Strobe 100-0% from fast to slow
		085-089	Strobe Open
		090-104	Strobe 0-100% from fast to slow
		105-109	Strobe Open
		110-124	Random strobe from slow to fast
		125-129	Strobe Open
		130-144	Random strobe 100-0% from slow to fast
		145-149	Strobe Open
		150-164	Random strobe 0-100% from slow to fast
		165-169	Strobe Open
		170-184	Pulse strobe 1 from fast to slow

		185-189	Strobe Open
		190-204	Random pulse strobe from slow to fast
		205-209	Strobe Open
		210-224	Strobe 100-0-100% from fast to slow
		225-229	Strobe Open
		230-244	Pulse strobe 1 from slow to fast
		245-255	Strobe Open
10	White Dimmer	000-255	0-100%
11	White Dimmer Fine	000-255	0-100%
12	White Strobe	000-019	Strobe Off
		020-024	Strobe Open
		025-064	Strobe from slow to fast
		065-069	Strobe Open
		070-084	Strobe 100-0% from fast to slow
		085-089	Strobe Open
		090-104	Strobe 0-100% from fast to slow
		105-109	Strobe Open
		110-124	Random strobe from slow to fast
		125-129	Strobe Open
		130-144	Random strobe 100-0% from slow to fast
		145-149	Strobe Open
		150-164	Random strobe 0-100% from slow to fast
		165-169	Strobe Open
		170-184	Pulse strobe 1 from fast to slow
		185-189	Strobe Open
		190-204	Random pulse strobe from slow to fast
205-209	Strobe Open		
210-224	Strobe 100-0-100% from fast to slow		
225-229	Strobe Open		
230-244	Pulse strobe 1 from slow to fast		
245-255	Strobe Open		
13	Red 1	000-255	0-100%
14	Green 1	000-255	0-100%
15	Blue 1	000-255	0-100%
16	Red 2	000-255	0-100%
17	Green 2	000-255	0-100%
18	Blue 2	000-255	0-100%
19	Red 3	000-255	0-100%
20	Green 3	000-255	0-100%
21	Blue 3	000-255	0-100%
22	Red 4	000-255	0-100%
23	Green 4	000-255	0-100%
24	Blue 4	000-255	0-100%
25	Red 5	000-255	0-100%

26	Green 5	000-255	0-100%
27	Blue 5	000-255	0-100%
28	Red 6	000-255	0-100%
29	Green 6	000-255	0-100%
30	Blue 6	000-255	0-100%
31	Red 7	000-255	0-100%
32	Green 7	000-255	0-100%
33	Blue 7	000-255	0-100%
34	Red 8	000-255	0-100%
35	Green 8	000-255	0-100%
36	Blue 8	000-255	0-100%
37	Red 9	000-255	0-100%
38	Green 9	000-255	0-100%
39	Blue 9	000-255	0-100%
40	Red 10	000-255	0-100%
41	Green 10	000-255	0-100%
42	Blue 10	000-255	0-100%
43	Red 11	000-255	0-100%
44	Green 11	000-255	0-100%
45	Blue 11	000-255	0-100%
46	Red 12	000-255	0-100%
47	Green 12	000-255	0-100%
48	Blue 12	000-255	0-100%
49	Red 13	000-255	0-100%
50	Green 13	000-255	0-100%
51	Blue 13	000-255	0-100%
52	Red 14	000-255	0-100%
53	Green 14	000-255	0-100%
54	Blue 14	000-255	0-100%
55	Red 15	000-255	0-100%
56	Green 15	000-255	0-100%
57	Blue 15	000-255	0-100%
58	Red 16	000-255	0-100%
59	Green 16	000-255	0-100%
60	Blue 16	000-255	0-100%
61	Red 17	000-255	0-100%
62	Green 17	000-255	0-100%
63	Blue 17	000-255	0-100%
64	Red 18	000-255	0-100%
65	Green 18	000-255	0-100%
66	Blue 18	000-255	0-100%
67	White 1	000-255	0-100%
68	White 2	000-255	0-100%
69	White 3	000-255	0-100%

70	White 4	000-255	0-100%
71	White 5	000-255	0-100%
72	White 6	000-255	0-100%
73	White 7	000-255	0-100%
74	White 8	000-255	0-100%
75	White 9	000-255	0-100%
76	White 10	000-255	0-100%
77	White 11	000-255	0-100%
78	White 12	000-255	0-100%
79	White 13	000-255	0-100%
80	White 14	000-255	0-100%
81	White 15	000-255	0-100%
82	White 16	000-255	0-100%
83	White 17	000-255	0-100%
84	White 18	000-255	0-100%
85	White 19	000-255	0-100%
86	White 20	000-255	0-100%
87	White 21	000-255	0-100%
88	White 22	000-255	0-100%
89	White 23	000-255	0-100%
90	White 24	000-255	0-100%
91	White 25	000-255	0-100%
92	White 26	000-255	0-100%
93	White 27	000-255	0-100%
94	White 28	000-255	0-100%
95	White 29	000-255	0-100%
96	White 30	000-255	0-100%
97	White 31	000-255	0-100%
98	White 32	000-255	0-100%
99	White 33	000-255	0-100%
100	White 34	000-255	0-100%
101	White 35	000-255	0-100%
102	White 36	000-255	0-100%
103	White 37	000-255	0-100%
104	White 38	000-255	0-100%
105	White 39	000-255	0-100%
106	White 40	000-255	0-100%
107	White 41	000-255	0-100%
108	White 42	000-255	0-100%
109	White 43	000-255	0-100%
110	White 44	000-255	0-100%
111	White 45	000-255	0-100%
112	White 46	000-255	0-100%
113	White 47	000-255	0-100%

114	White 48	000-255	0-100%
-----	----------	---------	--------

DMX 512 130CHs

CH	Function	Value	Percent/Setting
1	Tilt	000-255	0-100%
2	Fine tilt	000-255	0-100%
3	Dimmer Mode	000-020	None
		021-040	Off
		041-060	Dimmer 1
		061-080	Dimmer 2
		081-100	Dimmer 3
		101-255	None
4	Dimmer Curve	000-020	None
		021-040	Linear
		041-060	Index
		061-080	Logarithm
		081-100	S-Surve
		101-255	None
5	Frost	000-255	0-100%
6	Reset	000-250	None
		251-255	Reset after 5s
7	Total Dimmer	000-255	0-100%
8	RGB 1 Dimmer	000-255	0-100%
9	RGB 1 Dimmer Fine	000-255	0-100%
10	RGB 1 Strobe	000-255	Strobe
11	Red (RGB1-1)	000-255	0-100%
12	Green (RGB1-1)	000-255	0-100%
13	Blue (RGB1-1)	000-255	0-100%
14	Red (RGB1-2)	000-255	0-100%
15	Green (RGB1-2)	000-255	0-100%
16	Blue (RGB1-2)	000-255	0-100%
---	-----	-----	-----
---	-----	-----	-----

---	-----	-----	-----
26	Red (RGB1-6)	000-255	0-100%
27	Green (RGB1-6)	000-255	0-100%
28	Blue (RGB1-6)	000-255	0-100%
29	RGB 2 Dimmer	000-255	0-100%
30	RGB 2 Dimmer Fine	000-255	0-100%
31	RGB 2 Strobe	0-255	Strobe
32	Red (RGB2-1)	000-255	0-100%
33	Green (RGB2-1)	000-255	0-100%
34	Blue (RGB2-1)	000-255	0-100%
---	-----	-----	-----
---	-----	-----	-----
---	-----	-----	-----
47	Red (RGB2-6)	000-255	0-100%
48	Green (RGB2-6)	000-255	0-100%
49	Blue (RGB2-6)	000-255	0-100%
51	RGB 3 Dimmer	000-255	0-100%
52	RGB 3 Dimmer Fine	000-255	0-100%
53	RGB 3 Strobe	0-255	Strobe
54	Red (RGB3-1)	000-255	0-100%
55	Green (RGB3-1)	000-255	0-100%
56	Blue (RGB3-1)	000-255	0-100%
---	-----	-----	-----
---	-----	-----	-----
---	-----	-----	-----
68	Red (RGB3-6)	000-255	0-100%
69	Green (RGB3-6)	000-255	0-100%
70	Blue (RGB3-6)	000-255	0-100%
71	White 1 Dimmer	000-255	0-100%
72	White 1 Dimmer Fine	000-255	0-100%
73	White 1 Strobe	0-255	Strobe
74	White (1-1)	000-255	0-100%
75	White (1-2)	000-255	0-100%
76	White (1-3)	000-255	0-100%

78	White (1-4)	000-255	0-100%
79	White (1-5)	000-255	0-100%
80	White (1-6)	000-255	0-100%
81	White (1-7)	000-255	0-100%
82	White (1-8)	000-255	0-100%
83	White (1-9)	000-255	0-100%
84	White (1-10)	000-255	0-100%
85	White (1-11)	000-255	0-100%
86	White (1-12)	000-255	0-100%
---	-----	-----	-----
---	-----	-----	-----
---	-----	-----	-----
116	White 4 Dimmer	000-255	0-100%
117	White 4 Dimmer Fine	000-255	0-100%
118	White 4 Strobe	0-255	Strobe
119	White (4-1)	000-255	0-100%
120	White (4-2)	000-255	0-100%
121	White (4-3)	000-255	0-100%
122	White (4-4)	000-255	0-100%
123	White (4-5)	000-255	0-100%
124	White (4-6)	000-255	0-100%
125	White (4-7)	000-255	0-100%
126	White (4-8)	000-255	0-100%
127	White (4-9)	000-255	0-100%
128	White (4-10)	000-255	0-100%
129	White (4-11)	000-255	0-100%
130	White (4-12)	000-255	0-100%

DMX 512 170CHs

CH	Function	Value	Percent/Setting
1	Tilt	000-255	0-100%
2	Fine tilt	000-255	0-100%
		000-020	None
		021-040	Off
		041-060	Dimmer 1

3	Dimmer Mode	061-080	Dimmer 2
		081-100	Dimmer 3
		101-255	None
4	Dimmer Curve	000-020	None
		021-040	Linear
		041-060	Index
		061-080	Logarithm
		081-100	S-Surve
		101-255	None
5	Frost	000-255	0-100%
6	Reset	000-250	None
		251-255	Reset after 5s
7	Total Dimmer	000-255	0-100%
8	RGB 1 Dimmer	000-255	0-100%
9	RGB 1 Dimmer Fine	000-255	0-100%
10	RGB 1 Strobe	000-255	Strobe
11	Red (RGB1)	000-255	0-100%
12	Green (RGB1)	000-255	0-100%
13	Blue (RGB1)	000-255	0-100%
14	(RGB-1) Mode Effect	000-255	(RGB-1) Effect Speed
15	(RGB-1) Effect Speed	000-255	0-100%
16	RGB-1 Effect Gradual change	0-255	RGB-1 Effect Gradual change
17	RGB-1 Effect Background Color	000-255	RGB-1 Effect Background Color
18	RGB-1 Effect Background Dimmer	000-255	0-100%
19	Red (RGB1-1)	000-255	0-100%
20	Green (RGB1-1)	000-255	0-100%
21	Blue (RGB1-1)	000-255	0-100%
22	Red (RGB1-2)	000-255	0-100%
23	Green (RGB1-2)	000-255	0-100%
24	Blue (RGB1-2)	000-255	0-100%
----	-----	-----	-----
----	-----	-----	-----
----	-----	-----	-----
34	Red (RGB1-6)	000-255	0-100%
35	Green (RGB1-6)	000-255	0-100%
36	Blue (RGB1-6)	000-255	0-100%
----	-----	-----	-----

---	-----	-----	-----
---	-----	-----	-----
---	-----	-----	-----
---	-----	-----	-----
---	-----	-----	-----
69	Red (RGB3)	000-255	0-100%
70	Green (RGB3)	000-255	0-100%
71	Blue (RGB3)	000-255	0-100%
72	(RGB-3) Mode Effect	000-255	(RGB-3) Effect Speed
73	(RGB-3) Effect Speed	000-255	0-100%
74	RGB-3 Effect Gradual change	0-255	RGB-3 Effect Gradual change
75	RGB-3 Effect Background Color	000-255	RGB-3 Effect Background Color
76	RGB-3 Effect Background Dimmer	000-255	0-100%
77	Red (RGB3-1)	000-255	0-100%
78	Green (RGB3-1)	000-255	0-100%
79	Blue (RGB3 -1)	000-255	0-100%
80	Red (RGB3-2)	000-255	0-100%
81	Green (RGB3-2)	000-255	0-100%
82	Blue (RGB3-2)	000-255	0-100%
---	-----	-----	-----
---	-----	-----	-----
---	-----	-----	-----
92	Red (RGB3-6)	000-255	0-100%
93	Green (RGB3-6)	000-255	0-100%
94	Blue (RGB3-6)	000-255	0-100%
95	White 1 Dimmer	000-255	0-100%
96	White 1 Dimmer Fine	000-255	0-100%
97	White 1 Strobe	0-255	Strobe
98	White 1	0-255	0-100%
99	White 1 Effect	0-255	White 1 Effect
100	White 1 Effect	0-255	White 1 Effect Speed
	Speed		
101	White 1 Effect Gradual change	0-255	White 1 Effect Gradual change
102	White (1-1)	000-255	0-100%
103	White (1-2)	000-255	0-100%

104	White (1-3)	000-255	0-100%
105	White (1-4)	000-255	0-100%
106	White (1-5)	000-255	0-100%
107	White (1-6)	000-255	0-100%
108	White (1-7)	000-255	0-100%
109	White (1-8)	000-255	0-100%
110	White (1-9)	000-255	0-100%
111	White (1-10)	000-255	0-100%
112	White (1-11)	000-255	0-100%
113	White (1-12)	000-255	0-100%
----	-----	-----	-----
----	-----	-----	-----
----	-----	-----	-----
----	-----	-----	-----
----	-----	-----	-----
----	-----	-----	-----
----	-----	-----	-----
152	White 4 Dimmer	000-255	0-100%
153	White 4 Dimmer Fine	000-255	0-100%
154	White 4 Strobe	0-255	Strobe
155	White 4	0-255	0-100%
156	White 4 Effect	0-255	White 4 Effect
157	White 4 Effect	0-255	White 4 Effect Speed
	Speed		
158	White 4 Effect Gradual change	0-255	White 4 Effect Gradual change
159	White (4-1)	000-255	0-100%
160	White (4-2)	000-255	0-100%
161	White (4-3)	000-255	0-100%
162	White (4-4)	000-255	0-100%
163	White (4-5)	000-255	0-100%
164	White (4-6)	000-255	0-100%
165	White (4-7)	000-255	0-100%
166	White (4-8)	000-255	0-100%
167	White (4-9)	000-255	0-100%
168	White (4-10)	000-255	0-100%
169	White (4-11)	000-255	0-100%
170	White (4-12)	000-255	0-100%

Trouble Shooting

Following are a few common problems that may occur during operation. Here are some suggestions for easy troubleshooting:

- a. The unit does not work, no light and the fan does not work
 1. Check the connection of power and main fuse.
 2. Measure the mains voltage on the main connector.
 3. Check the power on LED.

- b. **Not responding to DMX controller**
 1. DMX LED should be on. If not, check DMX connectors, cables to see if link properly.
 2. If the DMX LED is on and no response to the channel, check the address settings and DMX polarity.
 3. If you have intermittent DMX signal problems, check the pins on connectors or on PCB of the unit or the previous one.
 4. Try to use another DMX controller.
 5. Check if the DMX cables run near or run alongside to high voltage cables that may cause damage or interference to DMX interface circuit.

Fixture Cleaning

The cleaning of internal and external optical lenses and/or mirrors must be carried out periodically to optimize light output. Cleaning frequency depends on the environment in which the fixture operates: damp, smoky or particularly dirty surrounding can cause greater accumulation of dirt on the unit's optics.

- Clean with soft cloth using normal glass cleaning fluid.
- Always dry the parts carefully.
- Clean the external optics at least every 20 days. Clean the internal optics at least every 30/60 days.

REMARK

The product has perfect performance and integrity packing.

All users should be strictly comply with the warning and operating instructions as stated.

Or we aren't in charge of any result by misusing.

Any damage resulting by misuse is not within the Company's warranty.

Any fault or problem caused by neglecting the manual is also not in the charge of dealers.

Errors and omissions for every information given in this manual excepted.

All information is subject to change without prior notice.