

BSWF HP1000

User Manual



Guangzhou Mitek Light Co.,LTD

Email: info@miteklight.com

Website: www.miteklight.com

Add: No. 21 Dongfeng Avenue, Automobile Industry Base, Huadu District, Guangzhou

TECHNICAL PARAMETERS

Light source

Light source specification: 800W LED module

Light source life: 20000 hours

Input voltage: AC100V-240V /50Hz-60Hz

Optical

Beam angle: electron linear zoom 5-50 degrees

Color rendering index: adjustable display mode, standard mode Ra > 70, high display mode >

90 Color mixing system: Independent CMY color mixing system

Color temperature adjustment: CTO color temperature correction (7200-3200K)

Light source color temperature: 7400K

Controls

Channel mode: 39CH

Control protocol: Standard DMX512 protocol

Signal interface: 3-core XLR signal input/output, optional 5-core

Display mode: LCD touch screen, can reverse 180 display

Energy saving sleep: Automatically enters the sleep state when the signal is disconnected, which is safe and energy saving

Software upgrade: software can be upgraded via DMX signal cable

Effect

Color plate: 1 color plate has 6 colors, can achieve two-way rainbow, half color effect Fixed

gobo : 4 fixed gobos, which can change speed and shake

Rotating gobo: 7 optional gobos (pluggable), variable speed jitter and two-way rotation

Effect tray: Super dazzling simulation of dynamic flames, gurgling water and other dynamic effects

Prism: 3 facet prisms, can be independently bidirectional rotation

Cutting system: 4 independent cutting pieces, each piece can be individually closed light, can be rotated 90

Dimming: 0-100% linear adjustment

Strobe: 0-25Hz fast electronic stroboscopic

Frost: 1 independent atomizer,0-100% linear atomization, light spot natural soft

Construction

Pan/Tilt: 540 °/270°, automatic return and 16Bit precision fine-tuning

Cooling system: efficient cooling system, intelligent speed fan, built-in temperature sensor, automatic cooling system

Product appearance: flame retardant, high temperature resistance, folding integrated hook

Protection level: IP20

Weight&Dimension

Net weight: 27.5KG

Product size: 38.5*27*69CM

Carton packing size: 82*40*55CM

G.W(Carton): 33KG

Flight case packing size:109*57*81CM(2in1)

G. W(Flight case): 102.2KG

CMY FILTER

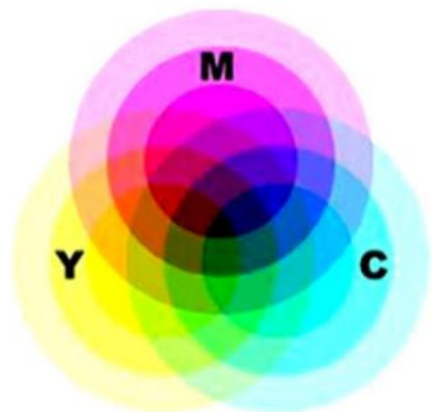

FRAME



Chapter 1 Installation and attention

1. Maintenance

- To reduce the risk of electrical shock or fire, do not expose this unit to rain or moisture.
- Intermittently using will extend this item's service life.
- Please clear the fan, fan net, and optical lens in order to keep good work state.
- Do not use the alcohol or any other organic solvent to wipe the shell.

2. Statement

The product has perfect performance and integrity packing. All users should be strictly complying with the warning and operating instructions as stated. Or we aren't in charge of any result by misusing. Any damage resulting by misuse is not within the Company's warranty. Any fault or problem caused by neglecting the manual is also not in the charge of dealers.

Note: All information is subject to change without prior notice.

3. Safety Precaution

- In order to guarantee the product's life, please don't put it in the damp places or even the environment over 60degrees.
- Always keep this unit in safe and stable matter.
- Install or dismantle should operate by professional engineer.
- In order to make sure the product is used well, please read the Manual carefully.

4. Cable connection (DMX)

Use a cable conforming to specifications EIA RS-485: 2-pole twisted, shielded, 120Ohm characteristic impedance, 22-24AWG, low capacity. Do not use microphone cable or other cable with characteristics differing from those specified. The end connections must be made using XLR type 3 or 5-pin male/female connectors. A terminating plug must be inserted into the last projector with a resistance of 120Ohm (minimum 1/4 W) between terminals 2 and 3.

IMPORTANT: The wires must not make contact with each other or with the metal casing of the connectors. The casing itself must be connected to the shield braid and to pin 1 of the connectors.

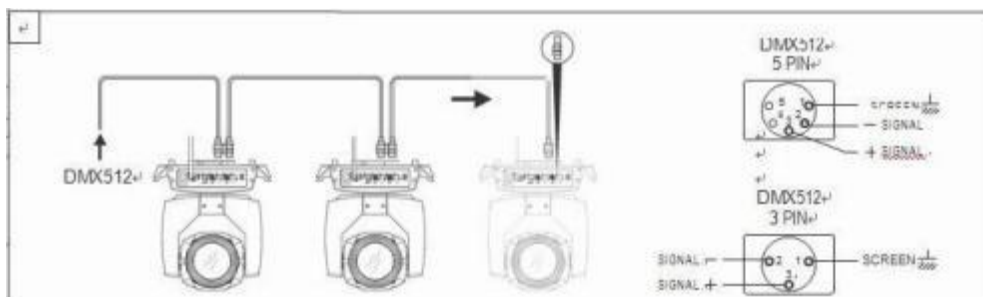

Figure 1 DMX Cable connection

5. Rigging (Optional)

This equipment can be positioned and fixed by clamp in every direction of the stage. Locking system makes it easy to fasten to the bracket.

Attention! Two clamps is needed to fix the equipment. Every clamp is locked by fastener of 1/4 kind. Fastener can only be locked clockwise.

Attention! Fasten a safety string to the additional hole of side aluminum piece. The secondary accessory can not hang on the delivery handle. Nip the equipment on bracket.

- Check if rigging clamp (not including the one inside) damaged or not? If stand ten times weight as the equipment. Make sure the architecture can stand ten times weight as all the equipments, clamps, wirings and other additional fixtures.
- Screws for clamping must be fixed firmly. Take one M12 screw (Grade 8.8 or higher) to clamp bracket, and then screw the nuts.
- Level the two hanging points at the bottom of clamp. Insert fastener to the bottom, lock the two levers by 1/4 rotating clockwise; then install another clamp.
- Install on safety string which stands at least ten times weight as equipment. Terminal of the accessory is designed for clamps.
- Make sure pan/tilt lock unlocked or not. Keep the distance more than 1M from equipment to flammable material or lighting source.

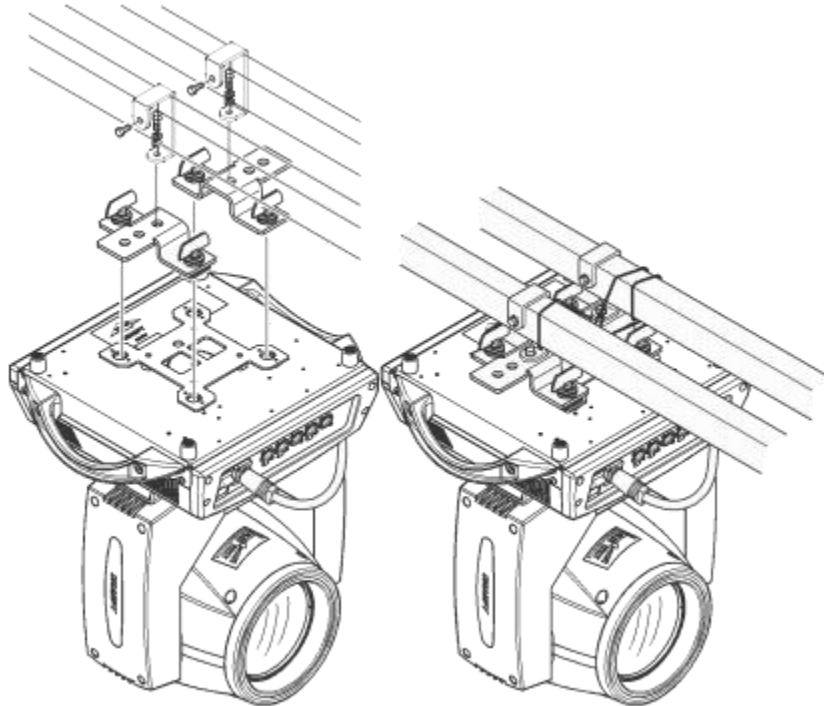

Figure 2 Installation

6. RDM Note

RDM is an extended version of DMX512-A protocol. It is a remote device management protocol.

Traditional DMX512 protocol communication is one-way communication. The protocol is based on RS-485 bus. RS-485 is a time-sharing multi-point, half-duplex protocol. Only one port is allowed to output at the same time. So, when using RDM, we should pay attention to it. The following points:

- To use console or host device that supports RDM host protocol.

- Use bidirectional signal amplifier, traditional one-way signal amplifier is not suitable for RDM protocol, because the RDM protocol needs feedback data, the use of one-way amplifier will block the return of data, resulting in no search fixture;
- All fixture must be set to DMX mode to ensure only one host on the cable.
- A 120 ohm impedance matching resistor must be inserted between terminals 2 and 3 of the terminal plug. When the signal line is longer, reducing the signal reflection will make the differential signal more stable and beneficial to the quality of communication.
- When the fixture appears to accept DMX control, but can not search by RDM host, first check the signal amplifier, and then check whether the signal line 2, 3 lines have bad contact.

Chapter 2 Panel operation

1. Brief

The light panel diagram show as Figure 3, above area is Title for fixture description, below area show fixture real-time status, such as DMX cable status, lamp status, error or information(ps. when there are message haven't been checked, echo 'ERR' in status bar, otherwise echo 'NOR').

Fixture TFT Displayer support touch, and right area is encoder or button, both of touch and coder button can operate fixture and setting.

Display & operation just like 'Android operation system', touch the item will set or modify setting.

RDM protocol is embed in fixture, user set DMX address via cable using the controller support RDM function. when fixture was searched by controller, displayer will echo 'RDM' indicate this RDM is working.

Note: Prevent damage of the touch or TFT displayer, Can not use sharp objects to chlick displayer.

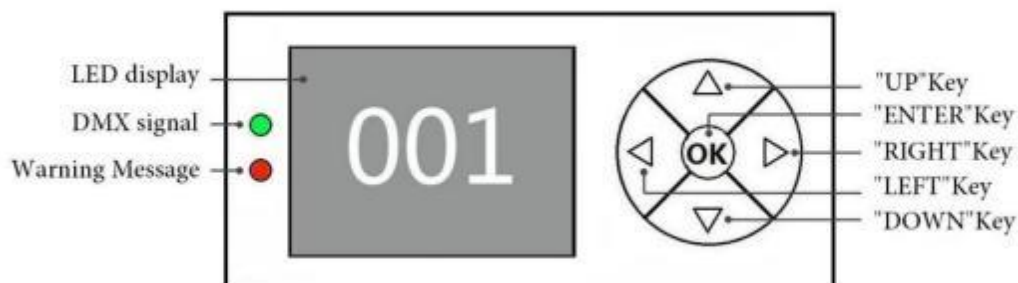

Figure 3 Panel diagram

Sub Menu (Parameter)



Figure 6 Parameter menu

2. Operation and parameter instruction

Chick item of main menu, enter corresponding sub menu shown in Figure 6, In main menu, chick 1/6 function button into corresponding parameter menu.

In sub menu(page), chick main item on the left side of displayer, can shift to corresponding sub menu(page) quickly.

1. DMX Address setting

Enter page show in Figure6-1, can set fixture DMX address, channel mode and so on.

The menu settings of fixture have optimized the setting of addresses. Several settings of the address are as follows:

- Select " previous " or "next", the fixture will be based on the current address and channel mode, automatically calculate the next or last address, make address setting can quickly;
- Click on the address value, you can enter the numeric editing window, where you can set any valid address, fixture system automatically get the current number of channels, automatically filter the unusable address (512 - the current number of channels).
- Fixture support RDM protocol, remote address can be set through RDM.

Provide two buttons:

- Channel mode: you can choose different channel modes by cycle.
- Fixture reset: reset all motors. Set Light work mode

2. Fixture operating mode setting

Through the page shown in Figure 6-2, the operating mode of the fixture can be set. The fixture supports five operating modes (DMX mode, auto mode, voice control mode .scene mode and Fan mode). Detailed parameter settings can be refer in the previous section. Specific parameter descriptions are as follows:

operating mode

DMX Mode	DMX mode, receive DMX signal, RDM signal	
Auto Run	Fixture run automatically according to built-in programs	
Sound Mode	When the fixture detects a strong sound, the fixture automatically runs a scene according to the built-in program, otherwise it will stay the last scene	
Scene Mode 01	runs in a set scene, which supports most of the custom editing of 10 scenes.	
	1~10	outputs the specified scene
	Auto	Automatically loops the output scene in the set scene time (non-zero) order, and the scene with time 0 automatically ignore
M/S Choose	Master and slave selection,non-DMX mode takes effect, select the mode of data output, fixture detect DMX cable state automatic switch output, prevent data conflicts	
	Master	fixture runs built-in program. If DMX has no signal, it outputs data (synchronization), otherwise it does not output data.
	Slave	fixture runs built-in program and do not output data
	Auto	If DMX has no signal, the fixture will runs built-in program. Otherwise, the fixture will run in DMX Mode(follow DMX).

Scene mode applies to a single or a small number of fixture, just output a fixed scene, or need to run a simple program, you no need connect to the console, in the scene page can be edited.

3. Set display

The fixture support Chinese and English, invert display and so on. Enter the corresponding parameter settings as shown in Figure 6-3. The specific menu contents are as follows:

DISPLAY SETTING

Language	display language settings	
	English	English display
	Chinese	Chinese display

Screen saver	Set screen 30 seconds without operation, the screen's display content or method.	
	OFF	Keep the last operation page
	Mode1	Black
	Mode2	Black screen, showing the address code of the current fixture in the lower left corner.
	Mode3	Display trademark information, address code and operation mode.
Screen Rot	Set the display direction of the screen.	
	OFF	No reverse display
	ON	Reverse display
	AUTO	Automatically detect the direction of lamps and automatically switch direction.
DMX Indicate	Set the indication mode of DMX signal indicator.	
	Mode1	When signal is bright, no signal is off.
	Mode2	When signal is off, no signal is bright.
	Mode3	When signal is flash, no signal is off.
Signal Bright	Set the brightness of the signal indicator	
	1~10	10
Screen Light	Set the screen backlight for 10 seconds without operation	
	1~10	10
Touch switch	Choose whether to disable the touch function. When the screen touch is accidentally damaged, you can disable the touch function and use auxiliary input to set the fixture.	
Touch	When the screen touch function work anomaly, you can enter the corrected page correction screen touch	

Which fixture support touch function, if there is a bad touch, you can enter the correction page to re-calibrate the touch accuracy of the touch screen, under normal circumstances, do not enter this page. If the touch is damaged, please choose to disable the touch switch.

4. Scene

Enter the page shown in Figure 6-4, and the fixture enters the scene editing mode. Under this page, the fixture does not receive DMX onsole data, and the edited data will effect on the fixture immediately.

The content of the page depends on the currently selected channel mode, and the channel content and order displayed are consistent with the fixture channel table. Through this page, you can edit 10 scenes, as shown in the following table:

SCENE MODE

Scene Select	Select the current operation scenario.	
	1~ 10	The 10 scenes sets the format
Scene Time	Sets the retention time of the current scene when it is automatic, unit in 0.1 seconds.	
	0	The current scene is not output in automatic scene output.
	1-255	0.. 1s-25.5s
1. PAN	0-255	Set up the data of each channel, and the contents and order of the display are one-to-one correspondence with the channel list of fixture.
.....	0-255	
.....	0-255	
N. Function	0-255	

If the reset channel in the scene edits the effective reset data, the fixture will reset, but after reset, the corresponding reset channel value will automatically set 0, preventing multiple consecutive resets. Looking at this page, you can get the current channel table slot of the fixture. For specific channel data, please refer to the detailed channel description.

5. Set light run parameter

Enter the page shown in Figure 6-5, adjust the field parameters of fixture, facilitate the installation of fixture, etc.

ADVANCED SETTING

ZG-Mode	Followspot Mode	
Pan Invert	Set the rotation direction of PAN	
	OFF	
	ON	
Tilt Invert	Set the rotation direction of TILT	
	OFF	
	ON	
P/T Rectify	Setting up fixture to detect XY lost step and correct	
	OFF	Uncorrected position after out of step
	ON	After losing step, the position is automatically corrected and the out of step fault is recorded.
Pan Offset	Setting the zero point of the PAN of the fixture	
	4-150	
Tilt Offset	Setting the zero point of the TILT of the fixture	
	4-48	
Data hold	When the fixture is not equipped with DMX signal, the output state of the fixture	
	OFF	No signal, so the motor and light source return to the position and state when reset is completed.
	ON	No signal, keep the last frame DMX data output.
Frame Mode	Mode1	
	Mode2	
Dimming Mode	Mode1	
	Mode2	
	Mode3	
Factory Setting	Pop up the confirmation box, select "SURE", and return the lamp parameters to the factory settings.	

When the fixture can't calibrate the position, please check if the "P/T Rectify" is turned off.

When the signal is unplugged, check the Data Hold setting first if the position of the fixture isn't output as expected.

When setting the XY offset, after setting up, please control XY with the maximum stroke first to check that XY will not bump into the positioning rod or shell.

6. Status and information

Entering the page shown in Figure 6-6, you can view the information and real-time status of the fixture to get their usage status. If the fixture need customer service, please provide the status information displayed on the page as a basis for judgment, as shown in the following table:

STATUS INFORMATION

Stepper info	Display information status of all motors and signals in fixture.	
	Hall	No display, indicating that the motor has no Hall, 0 indicating that the motor leaves the correction position point, 1 indicating that the motor is in the correction position point
	Status	Display motor reset status
	PAN	Display real-time position value of PAN optocoupler feedback
	TILT	Display real-time position value of TILT optocoupler feedback
	PAN OP	Displays the PAN TILT optocoupler two signal level state, binary
Error Logging	Show the latest 8 error records when the fixture is reset and running. The error records are not saved after power failure. The current power cycle is valid.	
	Error Logging	Total number of failures detected after power on
	12: :03	The time of power failure when the fault occurs is in minutes.
	Hall error	The effective hall signal is not detected when the motor is reset
	Hall short	When the motor is reset, the hall signal of the motor is always effective
	Optic error	No effective optocoupler signal is detected when the motor is reset.
	Lose stop	The corresponding motor is out of step during its operation.
	Hit	Striking the positioning rod when the motor is reset
	NTC error	The temperature sensor signal is abnormal
Fixture status	Displays the critical state data of the current fixture for reference.	
	Communication	0~ 100%, Communication quality of internal data link of lamps and lanterns
	Error count	The number of erroneous frames was detected after power on, and the total number of erroneous frames was detected.
	Light Temperature	Show the temperature of the current light source, "---" means no detection.
	Panel Temperature	Displays the temperature of the current display panel or the ambient temperature.
	Sensor1 Temperature	Display the ambient temperature of the motherboard temperature or the motherboard installation position.
Version	Display the information and version of the current fixture, important reference for after sales maintenance.	
	Device	The name of the fixture is the same as the equipment information of RDM.
	Model	The type of fixture is the same as the model information of RDM.
	Panel	Firmware version and serial number of display panel
	Main Board	Firmware version and serial number of mother board 1

Light time	Record the total cumulative time of light source opening, unit minute, user manual cleaning, as a reference for regular maintenance of light source time
Total time	The total accumulated time for recording the opening of fixture is not allowed to be removed.

Chapter 3 Channel description

1. Channel table

This luminaire channel can be viewed in scene mode in order, channel mode is set in the "Address Settings" page, specific details of the data as follows:

CHANNEL TABLE

CH1	FUNCTION	VALUE	DESCRIPTION
[CH1]	Cyan	0-255	Cyan
[CH2]	Magenta	0-255	Magenta
[CH3]	Yellow	0-255	Yellow
[CH4]	CTO	0-255	CTO
[CH5]	Color Macro	0-255	Used with CH6, 0~89 full color, 90~255 have half color function
[CH6]	Colour wheel		Used with CH5, 90~255
		0-4	White
		5-9	White+red
		10-14	Red
		15-19	Red+green
		20-24	Green
		25-29	Green+blue
		30-34	Blue
		35-39	Blue+pink
		40-44	Pink
		45-49	Pink+orange
		50-54	Orange
		55-59	Orange+peach
		60-64	Peach
		65-69	Peach+CTO
		70-127	Rotate reverse slow to fast
128-255	Linear color		
[CH7]	Strobe	0-3	Dark
		4-103	Pulse strobe slow to fast
		104-107	Open
		108-207	Fade strobe slow to fast
		208-212	Open

		213-251	Random strobe slow to fast
		252-255	Open
[CH8]	Dimmer	0-255	0-100% dimmer
[CH9]	Dimmer	0-255	Dimmer
[CH10]	Iris	0-255	Iris
[CH11]	Gobo	0-8	White
		9-17	Gobo1
		18-26	Gobo2
		27-35	Gobo3
		36-44	Gobo4
		45-53	Gobo3
		54-62	Gobo2
		63-71	Gobo1
		72-113	Rotate reverse fast to slow
		114-117	Stop
		118-159	Rotate forward slow to fast
		160-173	Shake slow to fast Gobo1
		174-187	Shake slow to fast Gobo2
		188-200	Shake slow to fast Gobo3
		201-214	Shake slow to fast Gobo4
		215-227	Shake slow to fast Gobo3
		228-241	Shake slow to fast Gobo2
242-255	Shake slow to fast Gobo1		
[CH12]	Rotate Gobo	0-10	White
		11-20	Gobo1
		21-30	Gobo2
		31-40	Gobo3
		41-50	Gobo4
		51-60	Gobo5
		61-65	Gobo6
		66-71	Gobo7
		72-113	Rotate reverse fast to slow
		114-117	Stop
		118-159	Rotate forward slow to fast
		160-175	Shake slow to fast Gobo1
		176-191	Shake slow to fast Gobo2
		192-207	Shake slow to fast Gobo3
		208-223	Shake slow to fast Gobo4
		224-239	Shake slow to fast Gobo5
		240-247	Shake slow to fast Gobo6
248-255	Shake slow to fast Gobo7		
		0-127	0-360 degrees

[CH13]	Gobo Autorotation	128-190	Rotate reverse (fast to slow)
		191-192	Stop
		193-255	Rotate forward (slow to fast)
[CH14]	Gobo Fine	0-255	Gobo Fine
[CH15]	Prism	0-127	No
		128-255	Insert prism1
[CH16]	Prism rotation	0-127	0-360 degrees
		128-190	Rotate forward (fast to slow)
		191-192	Stop
		193-255	Rotate reverse (slow to fast)
[CH17]	Effect entry	0-255	Use with CH18
[CH18]	Gobo effect	0-3	None
		4-255	Slow to fast
[CH19]	Frost	0-127	None
		128-255	Insert Frost
[CH20]	CRI	0-127	None
		128-255	Insert CRI
[CH21]	Focus	0-255	Far to near
[CH22]	Zoom	0-255	Small to big
[CH23]	Frame1	0-255	Frame1
[CH24]	Frame2	0-255	Frame2
[CH25]	Frame3	0-255	Frame3
[CH26]	Frame4	0-255	Frame4
[CH27]	Frame5	0-255	Frame5
[CH28]	Frame6	0-255	Frame6
[CH29]	Frame7	0-255	Frame7
[CH30]	Frame8	0-255	Frame8
[CH31]	Frame Rotation	0-255	Frame Rotation
[CH32]	Frame Macro	0-255	Frame Macro
[CH33]	Macro Speed	0-255	Macro Speed
[CH34]	Pan	0-255	0-540 degree
[CH35]	Pan Fine	0-255	0-2 degree
[CH36]	Tilt	0-255	0-270 degree
[CH37]	Tilt Fine	0-255	0-1 degree
[CH38]	Reset	0-25	None
		26-76	Reset Effect motor over 3 seconds
		77-127	Reset XY motor over 3 seconds
		128-255	Reset fixture over 3 seconds
[CH39]	Function	81-100	Mode1
		101-120	Mode2
		121-140	Mode3

Common faults and use attention

1. Common fault handling

The light source contains professional components such as microcomputer circuit board and high-voltage power supply. For your safety and product life, non-professionals should not disassemble the light source and related accessories without authorization.

1. The bulb does not light up (except LED light source)

Possible cause: The bulb is not completely cooled, or the bulb has reached the end of its life, the treatment is as follows:

- Due to abnormal operation, the bulb is not completely cooled down, so let the light source body cool down for more than 10 minutes to make the inside completely return to normal state, and then turn on the power again.;
- Check whether the bulb has reached the end of its life, and replace it with a new one;
- Check whether the bulb and the lighter circuit are leaking, falling off, or having poor contact;

I Replace with a new lighter.

2. The light beam appears dim

Possible cause: The bulb has been used for a long time or the light path is not clean, the treatment is as follows:

- Check whether the bulb has reached the end of its life, and replace it with a new one;
- Check whether the optical components or bulbs are clean, and whether there is dust on the bulbs and other optical components. Regular cleaning and maintenance of the bulbs and components in the light sources are required.

3. Fuzzy pattern projection

- Check whether the electronic focus channel value is suitable for the current projection distance.

4. The light sources work intermittently

Possible cause: The internal circuit enters the protection state, and the treatment is as follows:

- Check whether the fan is operating normally or whether it is dirty, causing the internal temperature of the light source to rise;
- Check whether the internal temperature control switch is closed;
- Check whether the bulb has reached the end of its service life, and replace it with a new one.

5. After the light source is reset normally, it does not accept the control of the console

Possible cause: signal line failure or abnormal light source parameter setting, the treatment is as follows:

- Check the start address code and check the connection of the DMX signal line (whether the signal line cable is intact, and whether the connection of the head is loose);
- Add signal amplifier, add 120 ohm terminal resistance;

6. The light source can't start

Possible cause: bad power line, the treatment is as follows:

- Check whether the fuse on the power input socket is fused, replace the fuse;
- light sources have poor line contact due to vibration during -distance transportation
- Check the input power, computer board and other pllongug-in devices.

2. Precautions for use

- Check whether the local power supply meets the requirements of the rated voltage of the product, and the leakage protector, overcurrent protector, etc. meet the requirements of the load;
- Do not use power cords with damaged insulation, and do not overlap power cords with other wires;

- The light source adopts strong air cooling, which is easy to accumulate dust. It must be cleaned once a month, especially the heat dissipation vent, otherwise it will be blocked by the accumulation of dust, resulting in poor heat dissipation and abnormalities in the light source.
- When installing the light source, the fixing screws must be fastened, with safety cables, and regular inspections;
- When installing and positioning the luminaire, keep a minimum distance of 10 meters between any point on the surface of the luminaire and any flammable and explosive object, and the distance from the irradiated object is 2.5 meters. Please do not install the luminaire directly on the surface of combustible materials.;
- It is recommended that the continuous working time of the light source should not exceed 10 hours, and the interval between continuous starting of the light source should not be less than 10 minutes, otherwise it will not be triggered normally due to the light source overheating protection;
- The closing time using the on-off valve should not exceed 5 minutes. If you need to close the light for a long time, you should use the console (lighting control channel) to turn off the light.;
- In order to ensure that multiple luminaires better comply with the scene effect, the luminaire should not be in the unfinished current scene all the time, that is, start the next scene action, it is best not to exceed 3 minutes in this state to ensure that multiple luminaires can run simultaneously;
- During use, if there is an abnormality in the light source, stop using the light source in time to prevent other malfunctions.

3. Precautions for using RDM

RDM is an extended version of the DMX512-A protocol. It is a remote device management protocol. The traditional DMX512 protocol communication is one-way communication. The protocol is based on the RS-485 bus. RS-485 is a time-sharing multi-point, half-duplex protocol. Only allowed at the same time One port is the output of the host, so, pay attention to the following points when using RDM:

- To use a console or host device that supports the RDM protocol host;
- To use a two-way signal amplifier, the traditional one-way signal amplifier is not suitable for the RDM protocol, because the RMD protocol requires feedback data, and the use of a one-way amplifier will block the returned data, resulting in the search for light sources and lanterns;
- All light sources must be set to DMX mode to ensure that there is only one host on the signal line;
- A 120ohm impedance matching resistor must be inserted between terminals 2 and 3 of the terminal plug. When the signal line is relatively long, the use of differential signals will be more stable when the signal line is relatively long, which is conducive to the quality of communication;

When it appears that the light source accepts DMX control, but cannot search for the light source by RDM, first check the signal amplifier, and then check whether there is a bad connection between the 2 and 3 lines of the signal line.

REMARK

The product has perfect performance and integrity packing.

All users should be strictly comply with the warning and operating instructions as stated.

Or we aren't in charge of any result by misusing.

Any damage resulting by misuse is not within the Company's warranty.

Any fault or problem caused by neglecting the manual is also not in the charge of dealers.

Errors and omissions for every information given in this manual excepted.

All information is subject to change without prior notice.